

# SO - Instrument Housing with Port-hole

## Description:

The SO instrument housing is made of aluminium alloy and circular shaped. It has a screwed cover with circular port-hole and has different configuration for cable entry. Please refer to the product SO-E showing this enclosure with extension.

## Application:

The SO instrument housing is suitable to contain signalling/ visualization equipment.

## Material:

Body and cover: copper free aluminium alloy.  
 Port-hole: thermo-resistant tempered glass.  
 Screws: stainless steel.

## Certification characteristics:

Type of Protection: II 2GD Ex d IIC / Ex tD A21  
 II 2GD Ex e II / Ex tD A21.  
 Class of Temperature: T6 / T85 °C,  
 T5 / T100 °C (only Ex e version).  
 Protection Degree: IP66 / IP67\*.  
 Certificate: INERIS 01ATEX0023.  
 Ambient Temperature: -50 / +60 °C (-20 / +40 °C).  
 Zones: 1 – 21 – 2 – 22.

## Threads:

NPT (ANSI B1.20.1).  
 Metric x 1.5 (ISO 261).

## Drawing SO

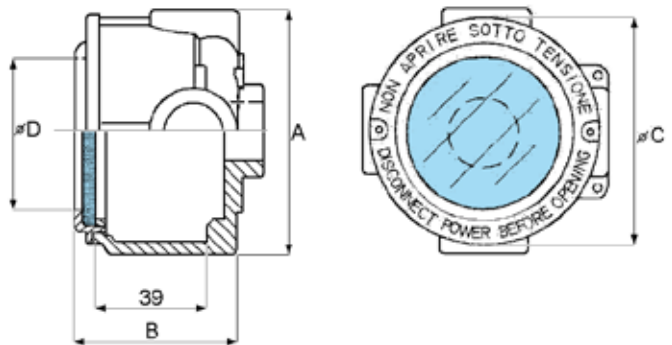

## Legend:

- A - Maximum external dimension.
- B - Maximum external dimension with cover.
- Ø C - External diameter.
- Ø D - Port-hole diameter.

Drawing dimensions [mm]

## On request:

- Stainless steel version AISI 304 or AISI316L.
- \*IP67 protection with o-ring.
- Anti loosening cover.
- Fixation brackets.
- External epoxy painting.
- Special inhibiting treatment.
- Cable glands for armoured or non armoured cable.

## SO - Data Table

Dimensions [mm] and approx. Weight [Kg]

Type	Entries		Dimensions				Weight	
	n°	Ø [NPT]	A	B	Ø C	Ø D		
	SO/A 16	1	1/2"	100	67	90	49	0,5
	SO/A 26	1	3/4"	100	67	90	49	0,5
	SO/B 16	2	1/2"	100	67	90	49	0,5
	SO/B 26	2	3/4"	100	67	90	49	0,5
	SO/C 16	2	1/2"	100	67	90	49	0,5
	SO/C 26	2	3/4"	100	67	90	49	0,5
	SO/D 16	3	1/2"	100	67	90	49	0,5
	SO/D 26	3	3/4"	100	67	90	49	0,5
	SO/L 16	2	1/2"	100	67	90	49	0,5
	SO/L 26	2	3/4"	100	67	90	49	0,5
	SO/M 16	3	1/2"	100	67	90	49	0,5
	SO/M 26	3	3/4"	100	67	90	49	0,5
	SO/T 16	3	1/2"	100	67	90	49	0,5
	SO/T 26	3	3/4"	100	67	90	49	0,5
	SO/W 16	4	1/2"	100	67	90	49	0,5
	SO/W 26	4	3/4"	100	67	90	49	0,5

Release date 2011-01-24 - Updated 2011-11-17 - A1

This datasheet does not constitute any contract obligation.

Pepperl+Fuchs reserves the right to modify the products herein illustrated without prior notice. Copyright Pepperl+Fuchs srl - Italy: +39 039 6292 1

Pepperl+Fuchs Group  
 www.pepperl-fuchs.com

USA: +1 330 486 0002  
 pa-info@us.pepperl-fuchs.com

Germany: +49 621 776 2222  
 pa-info@de.pepperl-fuchs.com

Singapore: +65 6779 9091  
 pa-info@sg.pepperl-fuchs.com