

Technical Description

Field termination: X10	Pressure clamp terminal	24 V DC / 6 mA , max. 100 mA per channel
System connector: X1A, X1B	50 pin YO50 (AKB331)	DI
Power feed: X20.3 ... 6	Redundant Power feed	24 V DC / 2 A, max. 3,15 A
Alarm: X20.1, X20.2	Power Alarm	Relay contact max. 30 V AC, 40 V DC, 2 A
F101; 117	Fuse channels 1...16 and 17...32	1 A, max. 1,5 A
F150; 151	Power feed fuse	2 A, max. 3,15 A
X20	6 pin screw terminal (removable)	Power feed terminal

Function: Termination-Board to connect to the Yokogawa CS 3000 R3 I/O card. The TB System connector X1A/X1B links to the Yokogawa I/O card via a standard cable supplied by Yokogawa. Two system connectors in parallel allow for redundant applications. The connections X10 to/from the field are clamp terminals. The unit has a 24 V DC redundant power supply feed, monitored by a potential free relay contact. (X20. 1, 2) LED PW1, PW2 and Alarm indicate the actual power status. Loops are powered directly from the board: 3-wire sensor, potential free contact, active voltage surge (see circuit diagram). Two groups (Ch. 1 ... 16 and Ch. 17 ... 32) are separately fused (F101, F117). Fuses are supervised and monitored by the Alarm relay. The board is designed to be mounted on DIN-Rail (DIN EN5022).

Circuit diagram

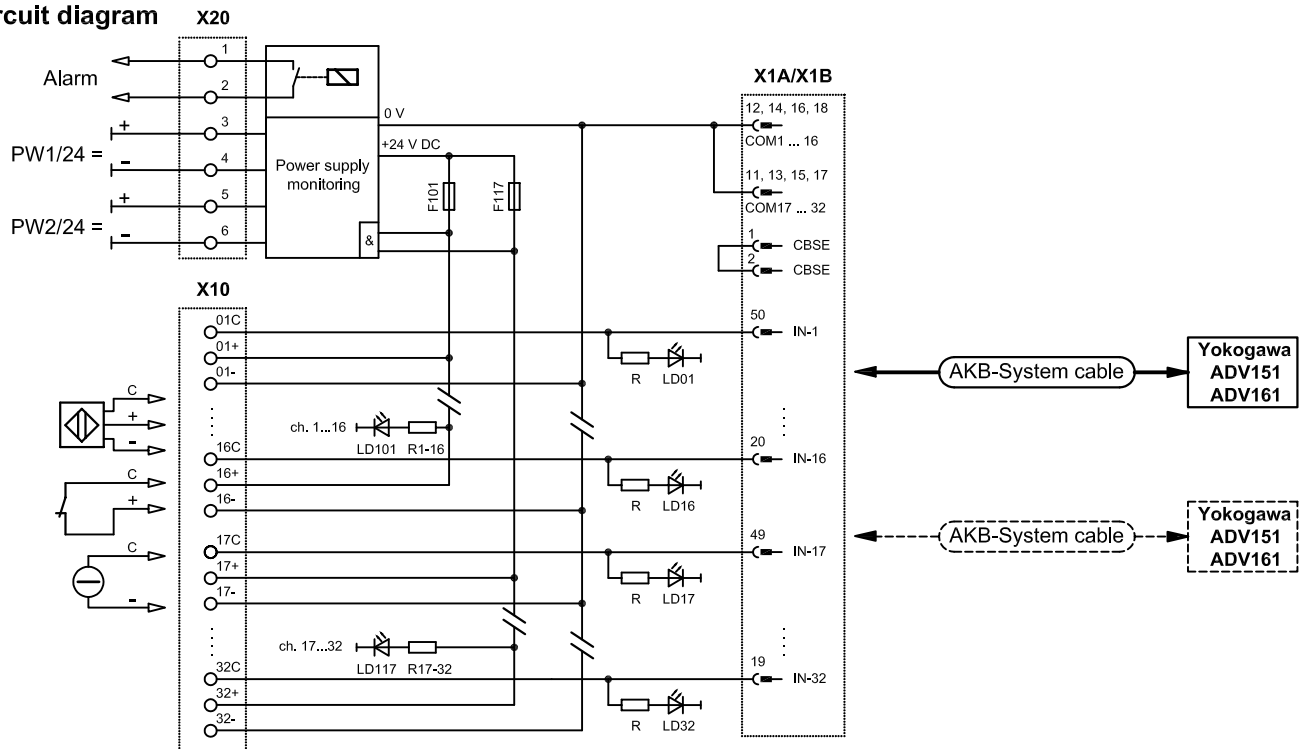

Options: TB-C3-DI32-SCSI50: PN XXXXX (36-9318_2) with SCSI connector

22.11.05	Bro	vB/Hi	Hi/vB	
Date	S TZ	Off. in ch.	contr. techn.	contr. Norm
Dept.: PA-PG-IF	No. 36-9318E1			
Up date: 02.11.10	Replaces: xxxxx / 36-xxxx		Sheet 1	
Scale: 1 : 2			of 3	

copyright according to DIN34 unauthorized distribution and reproduction prohibited

PEPPERL+FUCHS
Mannheim-Schönau

FI-Module
Non IS termination board
DI 32 channels - redundant
TB-C3-DI32-AKB-Y188683

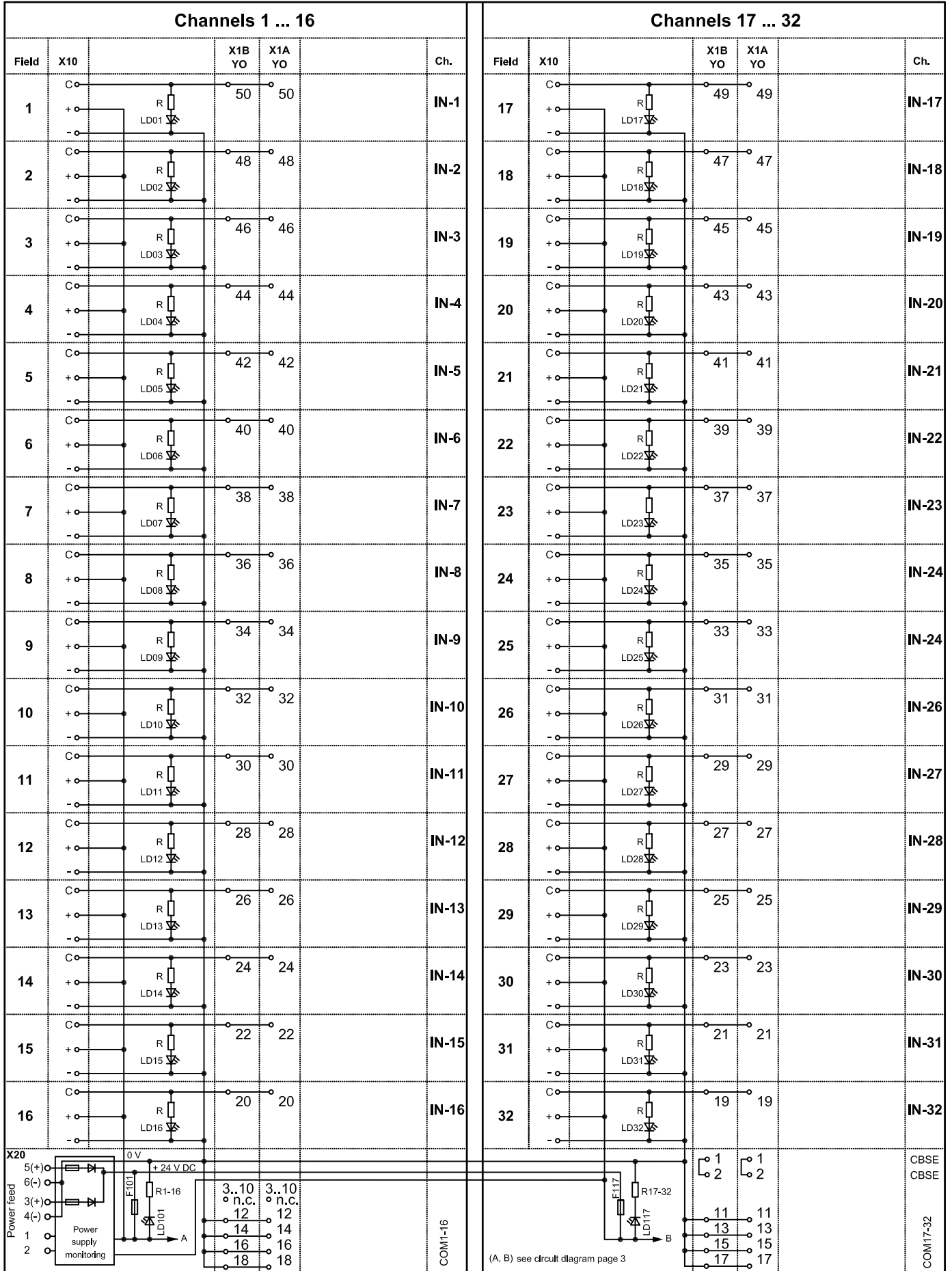

22.11.05	Bro	vB/Hi	Hi/vB	
Date	S TD	Off. in ch.	contr. techn.	contr. Norm
Dept.: PA-PG-IF	No. 36-9318E1			
Up date: 02.11.10	HB	Replaces: xxxxxx / 36-xxxx		Sheet 2
	Scale:	- :-	of	3



FI-Module
 Non IS termination board
 DI 32 channels - redundant
TB-C3-DI32-AKB-Y188683

Connection power supply and error message (Alarm)

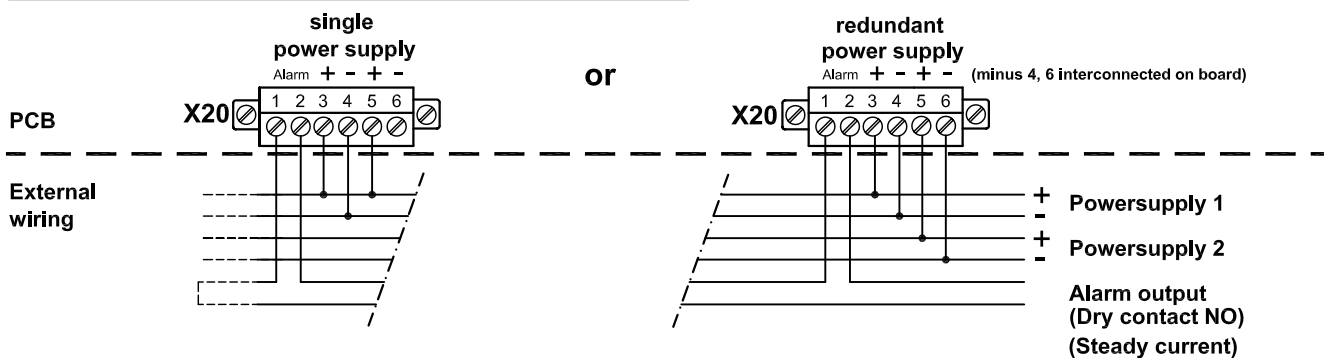

Alarm LD indication and contact status

Power supply 1	Power supply 2	LD green	X20.1, X20.2 Alarm contact	LD red (Flashing)
PS ON and Fuse 150 OK	PS ON and Fuse 151 OK	LD150 ON LD151 ON	contact closed	LD135 OFF
PS ON and Fuse 150 OK	PS OFF	LD150 OFF LD151 OFF	contact open	LD135 ON
PS OFF	PS ON and Fuse 151 OK	LD150 OFF LD151 ON	contact open	LD135 ON
PS ON and Fuse 150 OK	PS ON and Fuse 151 broken	LD150 ON LD151 OFF	contact open	LD135 ON
PS ON and Fuse 150 broken	PS ON and Fuse 151 OK	LD150 OFF LD151 ON	contact open	LD135 ON
PS ON and Fuse 150 broken	PS ON and Fuse 151 broken	LD150 OFF LD151 OFF	contact open	LD135 OFF
PS OFF	PS OFF	LD150 OFF LD151 OFF	contact open	LD135 OFF
F101 or 117 broken		LD101 OFF LD117 OFF	contact open	LD135 ON

copyright according to DIN34
unauthorized distribution and reproduction prohibited

	PEPPERL+FUCHS Mannheim-Schönau	FI-Module Non IS termination board DI 32 channels - redundant TB-C3-DI32-AKB-Y188683	22.11.05	Bro	vB/Hi	Hi/vB		
			Date	S	TD	Off. in ch.	contr. techn.	contr. Norm
			Dept.: PA-PG-IF	No. 36-9318E1			Replaces: xxxxx / 36-xxxx	Sheet 3
			Up date: 02.11.10	HB	Scale: -:-		of 3	