



**HR-3301**

- fully adjustable float switch system for up to 5 floats
- carrier material: PVC
- choice of terminal box and number of floats
- suitable for various types of floats

**Function:**

This float switch system made from PVC allows the freedom to change the fastening lengths and heights of the float fastening points if required. Adding up to 5 switching points at a later time can be done easily.

**Examples of applicable floats:**

Float	Data Sheet No.
HR-001	3100
HR-3102..	3102
HR-3103..	3102
HR-311500	3115
HR-31160.	3115
HR-31170.	3117
HR-3121..	3121

**Order No.:**

- (1) **Terminal box HR-330160**  
aluminium, PG 13.5 (on request)  
size A: 15 clamps  
size B: 6 clamps
- (2) **Screw fitting HR-330150**  
PVC, 1½" BSP, SW 55  
5 x cable leadthrough PG 9  
5 x PG 9 screw fitting PVC
- (3) **Clamping ring HR-330155**  
PVC, screw PVC  
1 x PG 9 screw fitting  
4 x cable leadthrough
- (4) **Guide tube HR-330151**  
PVC, dia. 16 x 2.5 x L  
(please specify length L)
- (5) **Float**

**Dimensions/components:**

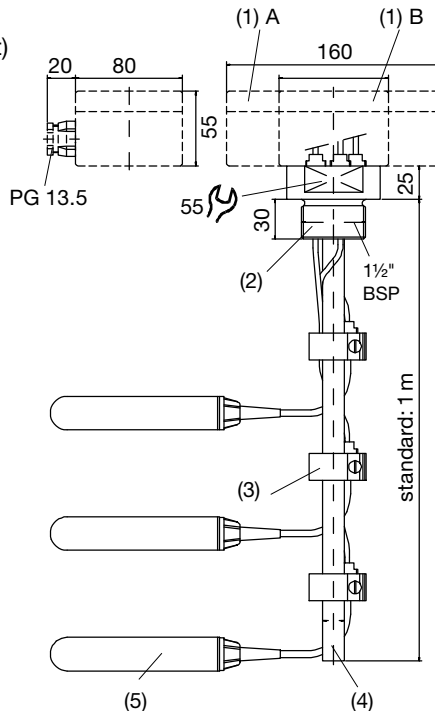

please specify the type of float switch and desired switching height when ordering

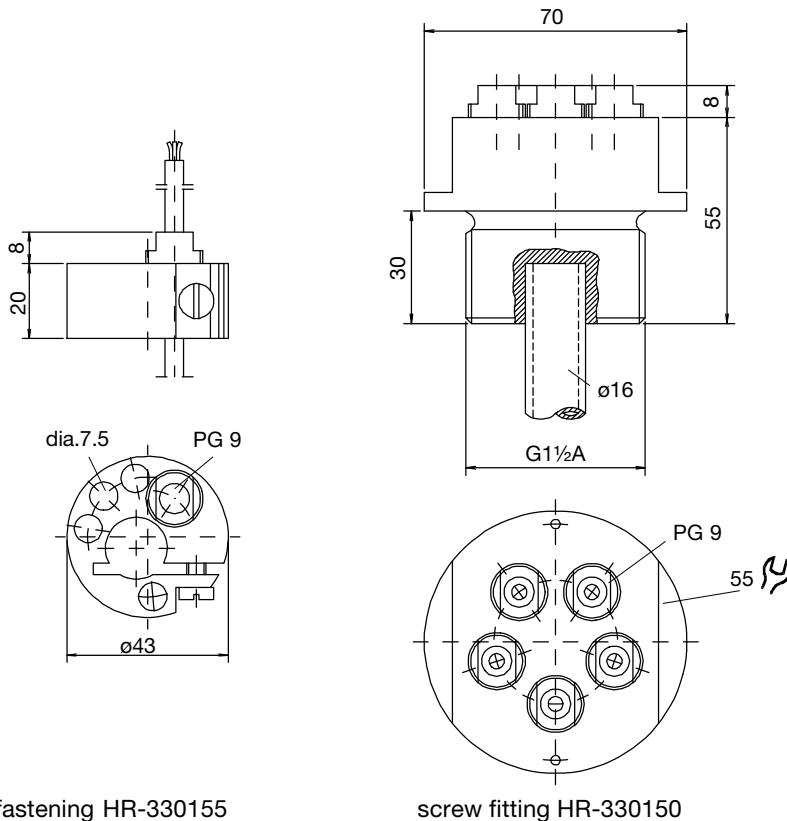

**Technical Data**

See the data sheets of the individual floats for information concerning the temperature and pressure ratings of the float and switching loads and functions of the switching elements.

Issue date 02.10.95