

- 2-Channel
- Control circuit EEx ia IIC Class I, Div 1, Groups A-G
- Reversible mode of operation
- 1 Signal output with 1 alternator
- EMC per NAMUR NE 21

DC 24 V:

KFD2-SR2-Ex2.W

replaces model KFD2-SR-Ex2
KHD2-SR2-Ex2.W

AC 115 V:

KFA5-SR2-Ex2.W

KHA5-SR2-Ex2.W

AC 230 V:

KFA6-SR2-Ex2.W

KHA6-SR2-Ex2.W

The transformer isolated barrier transfers digital signals from the hazardous area. Sensors per DIN 19 234 (NAMUR) and mechanical contacts may be used as alarms. The control circuit is monitored for lead breakage (LB).

AC units have a low heat build-up due to voltage peak value generation. This switching technique has been submitted for a patent.

The input is safely isolated from the output and the power supply per DIN EN 50 020. The output and power supply are safely isolated from each other in accordance with DIN VDE 0106 Section 101.

The outputs and power supply are galvanically isolated per DIN EN 50 178 for a design isolation voltage of AC 253 V.

The KF units are designed with removeable terminals and the KH units (Catalog Interface DIN-Rail Housing housing type D see page 15) with integrated terminals.

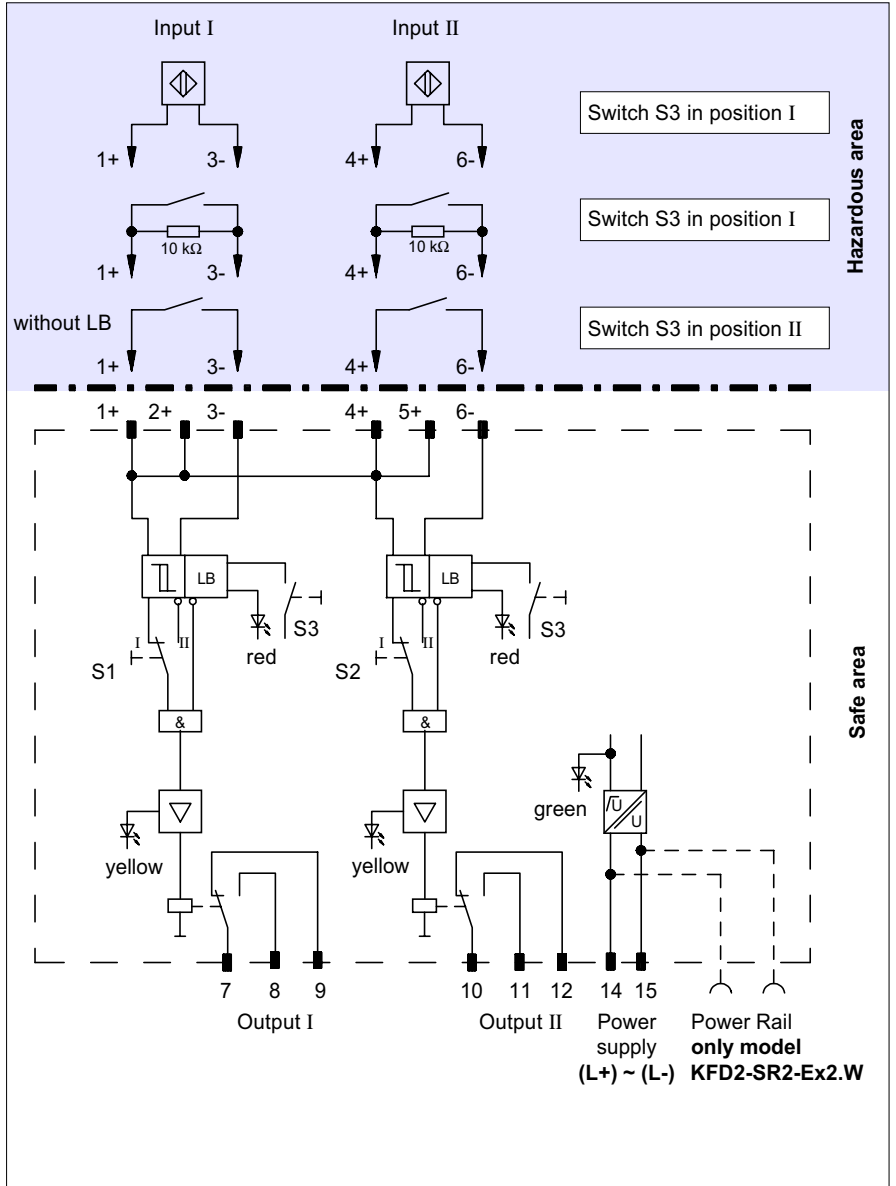

Front View

Housing type C
(see page 14)

LED yellow:
Relay output I

LED red:
LB channel I

LED yellow:
Relay output II

LED red:
LB channel II

removable terminals

LED green:
Power supply

Switch S1
(Mode of operation channel I)

Switch S2
(Mode of operation channel II)

Switch S3
(LB-monitoring)

removable terminals

29.05.98

P000288E



Technical data	KHD2-SR2-Ex2.W	KHA5-SR2-Ex2.W	KHA6-SR2-Ex2.W
Power supply Nominal voltage Maximum voltage U_m Ripple Nominal current Power consumption	Terminals 14 (L+), 15 (L-) DC 20 V ... 30 V DC 40 V $\leq 10\%$ ≤ 50 mA -	Terminals 14, 15 AC 103.5 V ... 126 V, 45 Hz ... 65 Hz DC 126.5 V - - ≤ 1.3 W	Terminals 14, 15 AC 207 V ... 253 V, 45 Hz ... 65 Hz DC 253 V - - ≤ 1.3 W
Input (Intrinsically safe) Nominal data Input pulse length / Input pulse interval Lead monitoring	Terminals 1+, 3-; 4+, 6- per DIN 19 234 or NAMUR, \approx DC 8 V / \approx 8 mA ≥ 20 ms / ≥ 20 ms Breakage $J \leq 0.1$ mA		
Certificate of Conformity Peak Values $U_0 / I_0 / P_0$ Allowable circuit values Ignition protection method, category Explosion group Max. external capacitance Max. external inductance Ignition protection method, category Explosion group Max. external capacitance Max. external inductance	PTB Nr. Ex-94.C.2086 for additional international approvals see page 384 10.5 V / 13 mA / 34 mW 10.6 V / 19 mA / 51 mW 10.6 V / 19 mA / 51 mW [EEx ia] IIB / IIC IIB / IIC IIB / IIC 2.1 μ F / 0.6 μ F 2.1 μ F / 0.59 μ F 2.1 μ F / 0.59 μ F 7 mH / 3 mH 5 mH / 3 mH 5 mH / 3 mH [EEx ib] IIB / IIC IIB / IIC IIB / IIC 22 μ F / 3 μ F 20 μ F / 2.9 μ F 20 μ F / 2.9 μ F 740 mH / 200 mH 360 mH / 100 mH 360 mH / 100 mH		
Entity Parameters Suitable for Div 2 installation/mounting Voltage V_{oc} Current I_{sc} Voltage V_t Current I_t Explosion group Max. external capacitance (C_a) Max. external inductance (L_a) Safety Parameters Safety Parameters	FM Control Drawing No. 116-0035 Terminals 4+, 6-; 5+, 6- No 12.9 V 19.8 mA - - A&B C&E D, F&G 1.273 μ F 3.82 μ F 10.18 μ F 84.88 mH 298.2 mH 744.4 mH CSA Control Drawing No. 116-0047 Terminals 4+, 6-; 5+, 6- 12.6 V / 650 Ohms		
Output (Not intrinsically safe) Output I: Output II: Contact load Mechanical life Energizing delay / De-energizing delay	Terminals 7, 8, 9 Terminals 10, 11, 12 AC: 253 V / 2 A / $\cos \varphi > 0.7$; DC: 40 V / 2 A ohmic load 10^7 Switchings ≈ 20 ms / ≈ 20 ms		
Transfer characteristics Switching frequency	≤ 10 Hz		
Galvanic isolation Input / Output Input / Power supply Output / Power supply Output / Output	Safe galvanic isolation per EN 50 020, voltage peak value 375 V Safe galvanic isolation per EN 50 020, voltage peak value 375 V Safe isolation per DIN VDE 0106, design isolation voltage 253 V _{eff} Basic insulation per DIN EN 50 178, design isolation voltage 253 V _{eff}		
Conformity to standard EMC / Electromagnetic compatibility	per EN 50 081-2 / EN 50 082-2, NAMUR NE 21		
Weight Ambient temperature	≈ 150 g (≈ 5.3 oz) -20 °C ... $+60$ °C (-4 °F ... 140 °F)		
	See page 12 for additional information on mechanical and electrical standards of the K-System.		