



Model Number

ASM58-0*

Features

- Industrial standard housing Ø58 mm
- 30 Bit multiturn
- Data transfer up to 2 MBaud
- Optically isolated RS 422 interface
- Recessed hollow shaft
- Zero-set function

Description

This multiturn absolute encoder with modern fast technology transmits a position value corresponding to the shaft setting via the SSI interface (Synchronous Serial Interface). The maximum resolution of the ASM58 is maximum 65536 steps per revolution at 16384 revolutions.

The devices of the ASM58 series are equipped with a microcontroller.

The control module sends a clock bundle to the absolute encoder to obtain position data. The rotary encoder then sends the position data synchronous to the cycles of the control module.

It is possible to select the following items with function inputs

- the counting direction and
- the zero-set function (preset value)

The absolute encoder is mounted directly onto the application shaft, without any coupling. Rotation of the absolute encoder is prevented by a torque rest.

The electrical connection is made by a 12-pin round plug connector. A version with a 1 m cable connector is also available.

Technical data

Functional safety related parameters

MTTF _d	150 a
Mission Time (T _M)	20 a
L _{10h}	1.9 E+11 at 6000 rpm and 20/40 N axial/radial shaft load
Diagnostic Coverage (DC)	0 %

Electrical specifications

Operating voltage U _B	10 ... 30 V DC
No-load supply current I ₀	max. 180 mA
Linearity	± 2 LSB at 16 Bit, ± 1 LSB at 13 Bit, ± 0,5 LSB at 12 Bit
Output code	Gray code, binary code
Code course (counting direction)	cw descending (clockwise rotation, code course descending)

Interface

Interface type	SSI
Monoflop time	20 ± 10 µs
Resolution	
Single turn	up to 16 Bit
Multiturn	14 Bit
Overall resolution	up to 30 Bit
Transfer rate	0.1 ... 2 MBit/s
Voltage drop	U _B - 2.5 V
Standard conformity	RS 422

Input 1

Input type	Selection of counting direction (V/R)
Signal voltage	
High	10 ... 30 V
Low	0 ... 2 V
Input current	< 6 mA
Signal duration	≥ 10 ms
Switch-on delay	< 0.001 ms

Input 2

Input type	zero-set (PRESET 1)
Signal voltage	
High	10 ... 30 V
Low	0 ... 2 V
Input current	< 6 mA
Signal duration	≥ 10 ms
Switch-on delay	< 100 ms

Connection

Connector	type 9416, 12-pin, type 9416L, 12-pin
Cable	Ø7 mm, 6 x 2 x 0.14 mm ² , 1 m

Standard conformity

Protection degree	DIN EN 60529, IP65
Climatic testing	DIN EN 60068-2-3, no moisture condensation
Emitted interference	EN 61000-6-4:2007
Noise immunity	EN 61000-6-2:2005
Shock resistance	DIN EN 60068-2-27, 100 g, 3 ms
Vibration resistance	DIN EN 60068-2-6, 10 g, 10 ... 2000 Hz

Ambient conditions

Operating temperature	-40 ... 85 °C (-40 ... 185 °F)
Storage temperature	-40 ... 85 °C (-40 ... 185 °F)

Mechanical specifications

Material	
Combination 1	housing: powder coated aluminium flange: aluminium shaft: stainless steel
Combination 2 (Inox)	housing: stainless steel flange: stainless steel shaft: stainless steel
Mass	approx. 460 g (combination 1) approx. 800 g (combination 2)
Rotational speed	max. 12000 min ⁻¹
Moment of inertia	50 gcm ²
Starting torque	< 5 Ncm
Shaft load	
Angle offset	± 0.9 °
Axial offset	static: ± 0.3 mm, dynamic: ± 0.1 mm
Radial offset	static: ± 0.5 mm, dynamic: ± 0.2 mm

Approvals and certificates

UL approval	cULus Listed, General Purpose, Class 2 Power Source
-------------	---

Dimensions

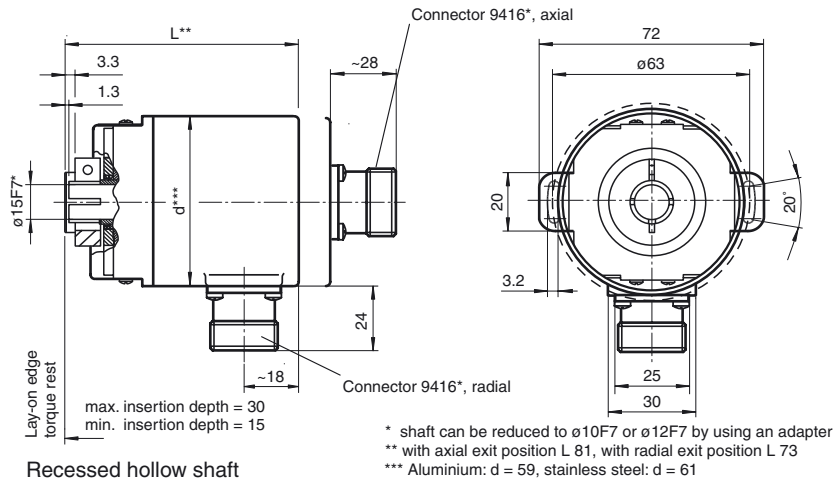

Recessed hollow shaft

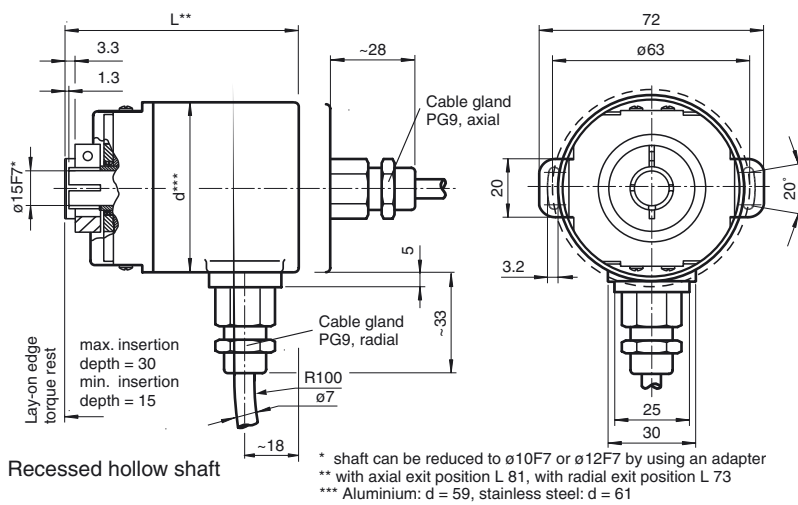

Recessed hollow shaft

Accessories

9416

Electrical connection

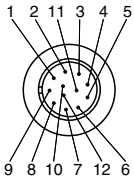
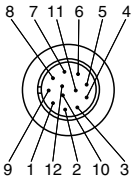
Signal	Cable Ø7 mm, 12-core	Connector 9416, 12-pin	Connector 9416L, 12-pin	Explanation
GND (encoder)	White	1	1	Power supply
U _b (encoder)	Brown	2	8	Power supply
Clock (+)	Green	3	3	Positive cycle line
Clock (-)	Yellow	4	11	Negative cycle line
Data (+)	Grey	5	2	Positive transmission data
Data (-)	Pink	6	10	Negative transmission data
Reserved	Blue	7	12	Not wired, reserved
V/R	Red	8	5	Input for selection of counting direction
PRESET 1	Black	9	9	zero-setting input
Reserved	Violet	10	4	Not wired, reserved
Reserved	Grey/Pink	11	6	Not wired, reserved
Reserved	Red/Blue	12	7	Not wired, reserved
				

Description

The Synchronous Serial Interface was specially developed for transferring the output data of an absolute encoder to a control device. The control module sends a clock bundle and the absolute encoder responds with the position value.

Thus only 4 lines are required for the clock and data, no matter what the resolution of the rotary encoder is. The RS 422 interface is optically isolated from the power supply.

SSI signal course Standard

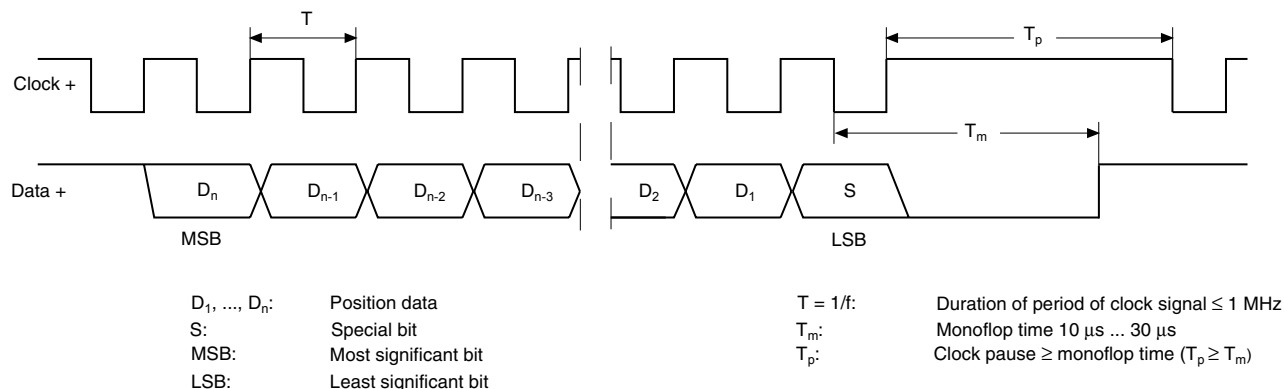

SSI output format Standard

- At idle status signal lines "Data +" and "Clock +" are at high level (5 V).
- The first time the clock signal switches from high to low, the data transfer in which the current information (position data (D_n) and special bit (S)) is stored in the encoder is introduced.
- The highest order bit (MSB) is applied to the serial data output of the encoder with the first rising pulse edge.
- The next successive lower order bit is transferred with each following rising pulse edge.
- After the lowest order bit (LSB) has been transferred the data line switches to low until the monoflop time T_m has expired.
- No subsequent data transfer can be started until the data line switches to high again or the time for the clock pause T_p has expired.
- After the clock sequence is complete, the monoflop time T_m is triggered with the last falling pulse edge.
- The monoflop time T_m determines the lowest transmission frequency.

SSI output format ring slide operation (multiple transmission)

- In ring slide operation, multiple transmission of the same data word over the SSI interface makes it possible to offer the possibility of detecting transmission errors.
- In multiple transmission, 25 bits are transferred per data word in standard format.
- If the clock change is not interrupted after the last falling pulse edge, ring slide operation automatically becomes active. This means that the information that was stored at the time of the first clock change is generated again.
- After the first transmission, the 26th pulse controls data repetition. If the 26th pulse follows after an amount of time greater than the monoflop time T_m , a new current data word will be transmitted with the following pulses.



If the pulse line is exchanged, the data word is generated offset.
Ring slide operation is possible up to max. 13 bits.

Block diagram

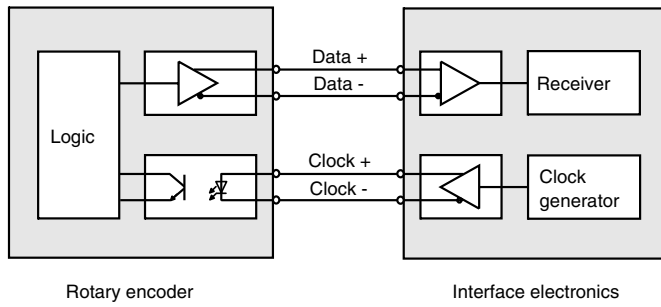

Line length

Line length in m	Baudrate in kHz
< 50	< 400
< 100	< 300
< 200	< 200
< 400	< 100

Inputs

The selection of the counting direction input (V/R) is activated with 0-level. The zero-set input (PRESET 1) is activated with 1-level.

zero-set input (PRESET 1)

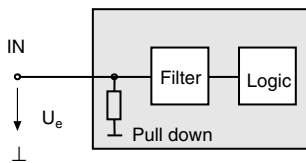

Input for selection of counting direction (V/R)

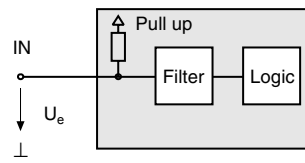

Accessories

Accessories	Name/defining feature	Order code
Connectors	Cable socket	9416
	Cable socket	9416L

For additional information on the accessories, please see the "Accessories" section.

Order code



- Number of bits singleturn**
 - 12 4096 (standard)
 - 13 8192
 - 16 65536
- Number of bits multiturn**
 - 12 4096 (standard)
 - 14 16384
- Output code**
 - B Binary
 - G Gray
- Exit position**
 - A Axial
 - R Radial
- Connection type**
 - K1 Cable Ø7 mm, 6 x 2 x 0.14 mm², 1 m
 - AA Plug connector type 9416, 12-pin
 - AB Plug connector type 9416L, 12-pin
- Shaft dimension/flange version**
 - F1A Recessed hollow shaft Ø10 mm x 30 mm
 - F2A Recessed hollow shaft Ø12 mm x 30 mm
 - F3A Recessed hollow shaft Ø15 mm x 30 mm
- Housing material**
 - N Aluminium, powder coated
 - I Inox*
 - W Aluminium, powder coated with shaft seal
- Principle of operation**
 - M Multiturn
- Shaft version**
 - S Recessed hollow shaft
- Data format**
 - A SSI (Synchronous Serial Interface)

*Housing material I only available with axial exit position.