



Model Number

PVS58*

Features

- Industrial standard housing Ø58 mm
- PROFIBUS interface
- 16 Bit singleturn
- Speed transfer
- Extended scaling functions
- Programmable limit switches
- Commissioning mode
- Servo or clamping flange

Description

This series of PROFIBUS rotary encoders is based on the modern fast technology of singleturn sampling. The absolute value rotary encoder corresponds to the PROFIBUS Profile for Encoders, Order No. 3.062. Operation is supported based on Class 1 and Class 2.

For operation based on Class 1, position data and diagnostic data bytes 1 ... 16 are available. In addition, the direction of the code can be selected as either cw ascending (clockwise rotation, code course ascending) or cw descending (clockwise rotation, code course descending).

If the rotary encoder is operated according to Class 2, additional functions to those from Class 1 are available. These include scaling of the resolution per revolution and the overall resolution, as well as the preset function. In addition, expanded diagnostic reporting is supported.

Besides, the rotary encoder offers extended functionalities such as speed transfer, extended scaling functions, programmable limit switches and a commissioning mode.

The removable connecting hood contains a slide switch for setting the terminating resistor and the rotary switches for setting the address. Assign a fixed address and bus termination to the encoder with this switches.

Technical data

Functional safety related parameters

MTTF _d	80 a
Mission Time (T _M)	20 a
L _{10h}	1.9 E+11 at 6000 rpm and 20/40 N axial/radial shaft load
Diagnostic Coverage (DC)	0 %

Electrical specifications

Operating voltage U _B	10 ... 30 V DC
Current consumption	max. 230 mA at 10 V DC, max. 100 mA at 24 V DC
Linearity	± 2 LSB at 16 Bit, ± 1 LSB at 13 Bit, ± 0,5 LSB at 12 Bit
Output code	binary code
Code course (counting direction)	programmable, cw ascending (clockwise rotation, code course ascending) cw descending (clockwise rotation, code course descending)

Interface

Interface type	PROFIBUS
Resolution	
Single turn	up to 16 Bit
Overall resolution	up to 16 Bit
Transfer rate	0.0096 ... 12 MBit/s
Standard conformity	PNO profile 3.062, RS 485

Connection

Terminal compartment	in removable housing cover
----------------------	----------------------------

Standard conformity

Protection degree	DIN EN 60529, shaft side: IP64 (without shaft seal)/IP66 (with shaft seal) housing side: IP65
Climatic testing	DIN EN 60068-2-3, no moisture condensation
Emitted interference	EN 61000-6-4:2007
Noise immunity	EN 61000-6-2:2005
Shock resistance	DIN EN 60068-2-27, 100 g, 6 ms
Vibration resistance	DIN EN 60068-2-6, 10 g, 10 ... 1000 Hz

Ambient conditions

Operating temperature	-40 ... 85 °C (-40 ... 185 °F)
Storage temperature	-40 ... 85 °C (-40 ... 185 °F)

Mechanical specifications

Material	
Combination 1	housing: powder coated aluminium flange: aluminium shaft: stainless steel
Combination 2 (Inox)	housing: stainless steel flange: stainless steel shaft: stainless steel
Mass	approx. 550 g (combination 1) approx. 1100 g (combination 2)
Rotational speed	max. 12000 min ⁻¹
Moment of inertia	30 gcm ²
Starting torque	≤ 3 Ncm (version without shaft seal)
Shaft load	
Axial	40 N
Radial	110 N

Approvals and certificates

UL approval	cULus Listed, General Purpose, Class 2 Power Source
-------------	---

Dimensions

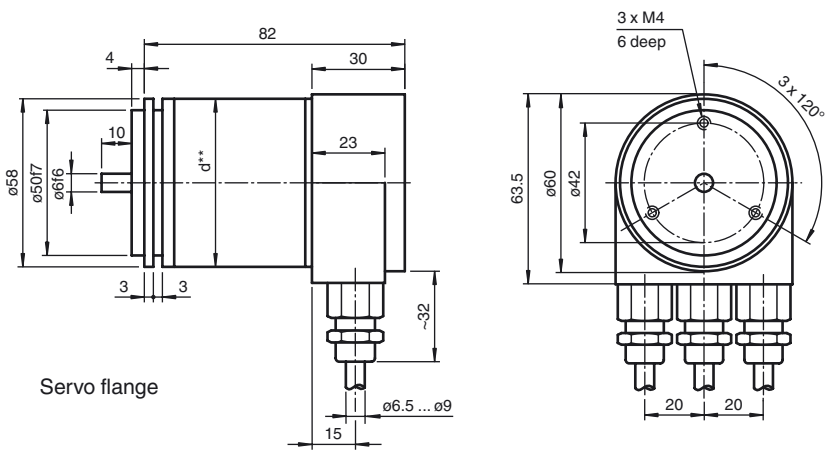

Servo flange

** Aluminium: d = 59, stainless steel: d = 61

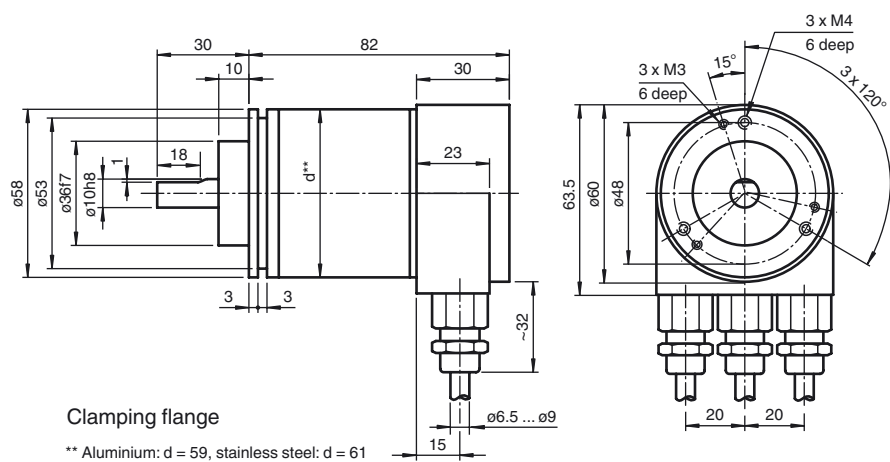

Clamping flange

** Aluminium: d = 59, stainless steel: d = 61

Accessories

Bushaube mit M12x1-Steckverbindern

Electrical connection

Terminal	Explanation
⊥	Ground connection for power supply
B (left)	Data line B (pair 1), Bus In
A (left)	Data line A (pair 1), Bus In
(-)	0 V
(+)	10 V ... 30 V
B (right)	Data line B (pair 2), Bus Out
A (right)	Data line A (pair 2), Bus Out
(-)	0 V
(+)	10 V ... 30 V
	The supply lines only have to be connected once (regardless to which terminal). The outgoing bus is being uncoupled while the terminal resistor is on.

The arrangement of the terminals is shown in the section operating elements.

Release date: 2011-03-10 14:39 Date of issue: 2011-03-10 T14445_ENG.xml

Indicating and operating elements

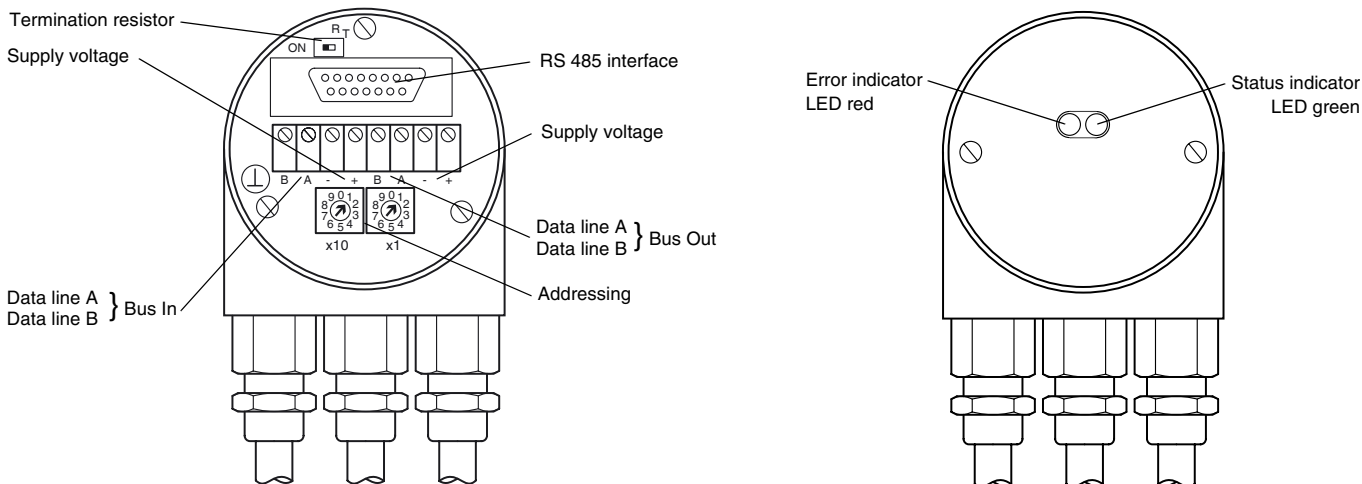

Adjusting the participant address

The participant address can be adjusted with the rotary switches. The address can be defined between 1 and 99, and may only be assigned once.

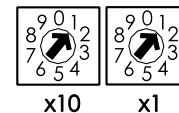

Adjusting the termination resistor

The terminating resistor R_T (121 Ω) can be connected to the circuit by means of the switch:

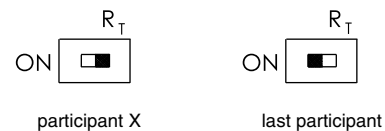

LED-indicators

LED red	LED green	Meaning
off	off	No voltage supply
an	on	Encoder ready, no configuration data received. possible reasons: - wrong address adjusted - wrong bus wiring
on	flashing	Parameterising or configuration error. Encoder receives data of incorrect length or inconsistent data. possible reason: - adjusted encoder resolution exceeds
flashing	on	Encoder ready, no communication (i.e. wrong address adjusted)
on	off	Data timeout (> 40 s). (i.e. data lines interrupted)
off	on	Normal operation, Data Exchange Mode
off	flashing	Installation Mode in Data Exchange Mode.

Principle of data transmission

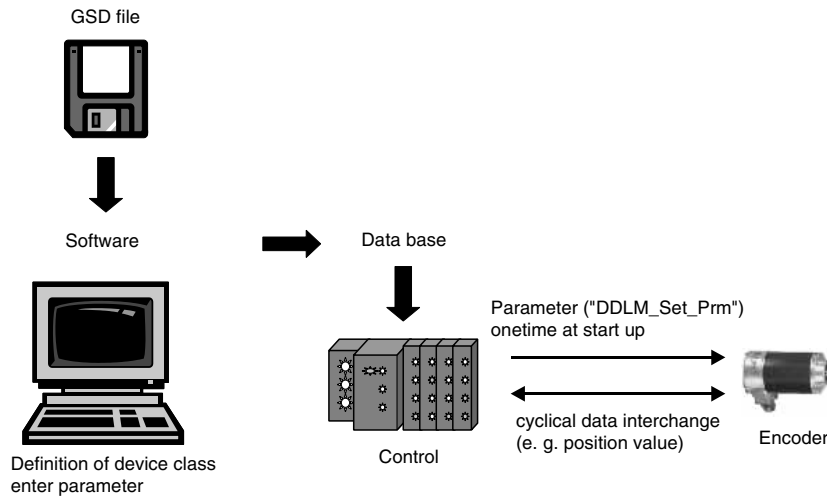

Parameter table encoder classes P+F 2.1 and P+F 2.2

Octet number (Byte)	Parameter	Bit number
1...8	PROFIBUS standard parameters	
9	Direction of rotation	0
	Class 2 functionality	1
	Commissioning Diagnostics	2
	Scaling function	3
	Reserved	4
	Reserved	5
	Activate manufacturer specific parameters (Octet 26)	6
	Reserved	7
10 ... 13	Desired measuring steps (reference: Octet 26, Bit 0 and 1)	
14 ... 17	Overall resolution	
18 ... 25	Reserved	
26	Reference for desired measuring steps	0
		1
	Activate commissioning mode	2
	Reduced diagnosis	3
	Reserved	4
	Activate lower software limit switch	5
	Activate upper software limit switch	6
	Activation of the parameters from Octet 27	7
27 ... 30	Lower limit switch	
31 ... 34	Upper limit switch	
35 ... 38	Physical measuring steps	
39	Reserved	0
	Rotary encoder type (singleturn or multiturn)	1
	Reserved	2
	Reserved	3
	Selection of the unit for speed transfer	4
		5
	Reserved	6
	Reserved	7

Release date: 2011-03-10 14:39 Date of issue: 2011-03-10 T14445_ENG.xml

Accessories

For type	Accessories	Name/defining feature	Order code
PVS58*-011	Couplings	D1: Ø10 mm, D2: Ø10 mm	9401
		D1: Ø10 mm, D2: Ø10 mm	9404
		D1: Ø10 mm, D2: Ø10 mm	9409
		D1: Ø10 mm, D2: Ø10 mm	KW
	Measurement wheels with circumference of 500 mm	Plastic	9101, 10
		Pimpled rubber	9102, 10
		Knurled aluminium	9103, 10
		Knurled plastic	9112, 10
	Measurement wheels with circumference of 200 mm	Plastic	9108, 10
		Pimpled rubber	9109, 10
		Knurled aluminium	9110, 10
	Mounting aids	Mounting bracket	9203
		Mounting bracket	9213
	PVS58*-032	Couplings	D1: Ø6 mm, D2: Ø6 mm
D1: Ø6 mm, D2: Ø6 mm			9402
D1: Ø6 mm, D2: Ø6 mm			9404
D1: Ø6 mm, D2: Ø6 mm			9409
D1: Ø6 mm, D2: Ø6 mm			KW
Mounting aids		Mounting bracket and set	9300 and 9311-3
		Eccentric clamping elements	9310-3

For additional information on the accessories, please see the "Accessories" section.

Order code

P V S 5 8 - - - - R 0 B N - 0 0 - - -

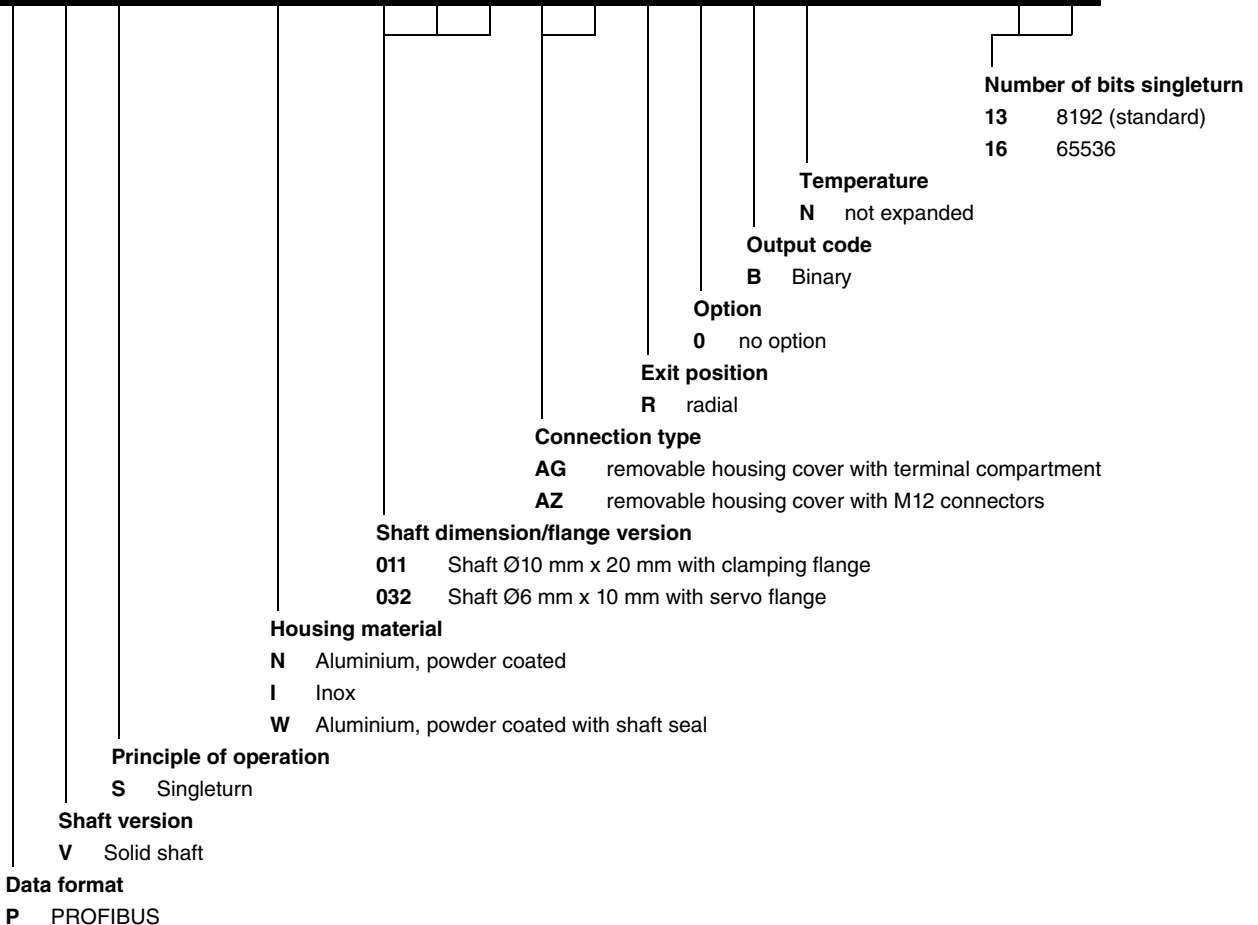

Release date: 2011-03-10 14:39 Date of issue: 2011-03-10 T14445_ENG.xml