



Model Number

OMH-ML17-EZ

Mounting bracket

Features

- Mounting bracket
- Simple and fast mounting
- Mounts in 25.4 mm (+/- 0.127 mm) diameter hole
- No nuts, screws, or tools required
- For 10 or 12 gauge walls

Dimensions

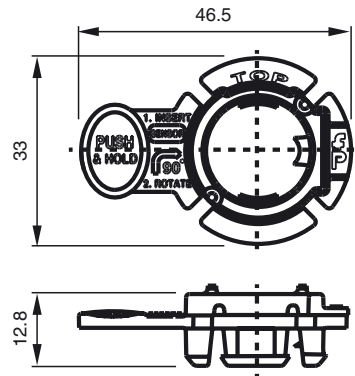

Technical data

Mechanical specifications

Material ABS

Suitable series

Series ML17

Note**Instructions**

Insert the bracket into the 25.4 mm (1-inch) diameter punch-out hole.



Insert the sensor into the bracket as shown.



Holding the bracket by the tab, rotate the sensor 90° clockwise.



Installed sensor shown from reverse angle.

