



Model Number

ML5-8-400/32/115a

Diffuse mode sensor
with 2 m fixed cable and 3-pin, M8 cable connector

Features

- Miniature design
- Infrared light design
- Light/dark ON, switchable
- Pre-fault indication
- Protection degree IP67
- Thru-holes for screw mounting

Dimensions

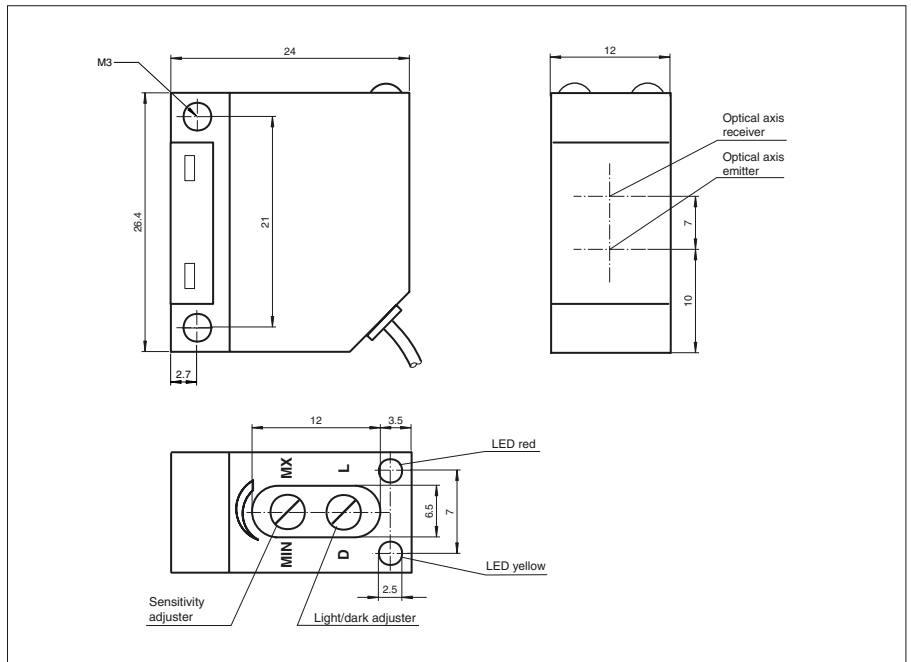

Electrical connection

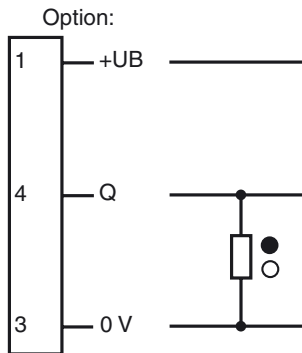

Pinout



Release date: 2010-05-03 10:46 Date of issue: 2010-05-03 801014_ENG.xml

Subject to modifications without notice

Pepperl+Fuchs Group
www.pepperl-fuchs.com

USA: +1 330 486 0001
fa-info@us.pepperl-fuchs.com

Germany: +49 621 776-4411
fa-info@pepperl-fuchs.com

Copyright Pepperl+Fuchs
Singapore: +65 6779 9091
fa-info@sg.pepperl-fuchs.com

Technical data**General specifications**

Detection range	0 ... 400 mm
Adjustment range	150 ... 400 mm
Reference target	standard white 100 mm X 100 mm
Light source	LED, Infrared 950 nm
Light type	modulated infrared light
Approvals	CE, cULus Listed 57M3 (Only in association with UL Class 2 power supply; Type 1 enclosure)
Ambient light limit	≤ 20000 Lux sun light ≤ 5000 Lux halogen light

Indicators/operating means

Function display	LED yellow: switching state LED red: pre-fault indication
Controls	light/dark switch, sensitivity adjuster

Electrical specifications

Operating voltage	U_B	10 ... 30 V DC
Ripple		10 %
No-load supply current	I_0	≤ 30 mA

Output

Switching type	light/dark on, switchable	
Signal output	1 PNP output, short-circuit proof, protected from reverse polarity, open collector	
Switching voltage	max. 30 V DC	
Switching current	max. 200 mA	
Voltage drop	U_d	≤ 2.5 V
Switching frequency	f	≤ 500 Hz
Response time		1 ms

Standard conformity

Standards	EN 60947-5-2
-----------	--------------

Ambient conditions

Ambient temperature	-25 ... 70 °C (-13 ... 158 °F)
Storage temperature	-25 ... 70 °C (-13 ... 158 °F)

Mechanical specifications

Protection degree	IP67 according to EN 60529
Connection	2 m, 3 x 0.14 mm ² , PUR cable
Material	
Housing	Polycarbonate
Optical face	PMMA
Mass	approx. 45 g

Compliance with standards and directives

Standard conformity	
Standards	EN 60947-5-2

Approvals and certificates

UL approval	cULus Listed, Type 1 enclosure
-------------	--------------------------------

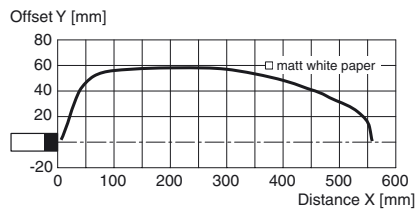
Curves/Diagrams**Characteristic response curve**

Permissible distance (offset) between optical axis and object.

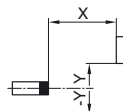
**Accessories**

OMH-ML5
Mounting aid

Additional Information**Conventional use:**

The reflex light scanner contains the emitter and receiver in a single housing. The light from transmitter is beamed back from the recorded object is evaluated by the receiver. The detection range depends on the object colour. With dark or very small objects the detection range reduces.

Mounting instructions:

The sensor can be fastened over the through-holes directly or with a mounting bracket (not included in scope of supply). The base surface must be flat to avoid distorting the housing during mounting. It is advisable to secure the bolts and screws with washers so that the sensor does not become misaligned.

Instructions for adjustment:

Adjust the sensor to the background. If the yellow LED is on now, the detection range needs to be reduced with the detection range adjuster, until the yellow LED goes off.

Object detection check:

Position the object into the light beam. Position light spot on object. If the object is detected, the yellow LED is illuminated. If not, adjust the detection range with the potentiometer, until the yellow LED lights up.

The red LED flashes if reception deteriorates (e.g. soiled lenses or by maladjustment) and when falling short of the stability control.

Illustration:

We recommend that you clean the optical interfaces and check the plug-in connections and screw connections at regular intervals.