

**Features**

- 4-channel
- Outputs wired to Ex e terminals
- Installation in suitable enclosures in Zone 1 or Zone 21
- Analog output module for 0/4 mA ... 20 mA
- HART communication via field bus or service bus
- Simulation mode for service operations (forcing)
- Line fault detection (LFD)
- Output with watchdog
- Permanently self-monitoring
- Up to SIL2 acc. to IEC 61508

**Function**

The analog output drives positioners, proportional valves, I/P converters, or local indicators.

Open circuit line fault alarms are detected, depending on the parameter setting.

The outputs can be switched off via a contact. This can be used for bus-independent safety applications.

The outputs are galvanically isolated from the bus and the power supply (EN 60079-11).

**Assembly**

Front view

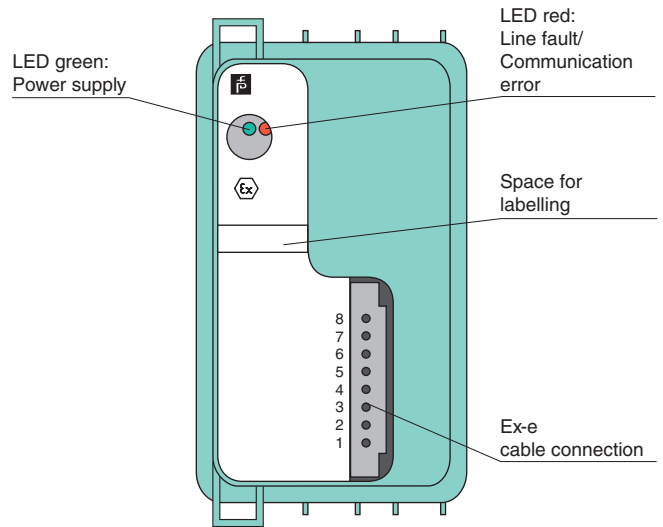

**Connection**

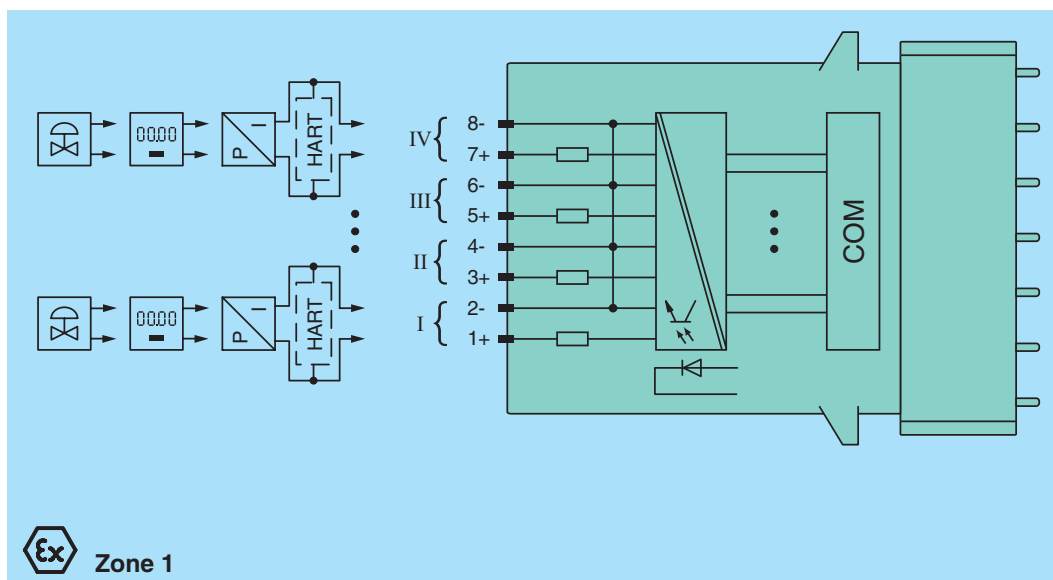

Release date 2012-12-10 11:50 Date of issue 2012-12-10 542154\_eng.xml

<b>Supply</b>	
Connection	backplane bus
Rated voltage	12 V DC , only in connection with the power supplies FB92**
Power consumption	3 W
<b>Internal bus</b>	
Connection	backplane bus
Interface	manufacturer specific bus to standard Com Unit/gateway
<b>Output</b>	
Connection	wire ends 1+ (white), 2- (brown), 3+ (green), 4- (yellow), 5+ (grey), 6- (pink)
Current	4 ... 20 mA (0 ... 25 mA) short-circuit protected
Load	750 Ω max.
Line fault detection	min. 1 mA
Response threshold	≥ 850 Ω
Watchdog	output off 0.5 s after serious fault
<b>Transfer characteristics</b>	
Deviation	0.1 % of the input signal range at 20 °C (68 °F)
Influence of ambient temperature	0.01 %/K of the input signal range
Refresh time	approx. 58 ms (4 channels) 110 ms during HART
<b>Indicators/settings</b>	
LED indicator	LED green: supply LED red: line fault , communication error
Labeling	space for labeling at the front
<b>Directive conformity</b>	
Electromagnetic compatibility	
Directive 2004/108/EC	EN 61326-1
<b>Conformity</b>	
Electromagnetic compatibility	NE 21
Protection degree	IEC 60529
Environmental test	EN 60068-2-14
Shock resistance	EN 60068-2-27
Vibration resistance	EN 60068-2-6
Damaging gas	EN 60068-2-42
Relative humidity	EN 60068-2-56
<b>Ambient conditions</b>	
Ambient temperature	-20 ... 60 °C (-4 ... 140 °F)
Storage temperature	-25 ... 85 °C (-13 ... 185 °F)
Relative humidity	95 % non-condensing
Shock resistance	shock type I, shock duration 11 ms, shock amplitude 50 m/s <sup>2</sup> , number of shock directions 6, number of shocks per direction 100
Vibration resistance	frequency range 5 ... 500 Hz, amplitude 5 ... 13.2 Hz ± 1.5 mm, 13.2 ... 100 Hz 1g, sweep rate 1 octave/min, duration 10 sweeps 5 Hz - 100 Hz - 5 Hz
Damaging gas	for plugs: 21 days in 25 ppm SO <sub>2</sub> , at 25 °C and 75 % rel. humidity, device G3
<b>Mechanical specifications</b>	
Protection degree	IP20 (module) , a separate housing is required acc. to the system description
Connection	wire ends or shielded cable tail wiring connection separately covered Ex e terminals required
Mass	approx. 750 g
Dimensions	57 x 107 x 132 mm (2.2 x 4.2 x 5.2 in)
<b>Data for application in connection with Ex-areas</b>	
EC-Type Examination Certificate	PTB 97 ATEX 1074 U , PTB 97 ATEX 1075 (system) , for additional certificates see <a href="http://www.pepperl-fuchs.com">www.pepperl-fuchs.com</a>
Group, category, type of protection	⊕ II 2 G Ex d IIC
Electrical isolation	
Output/power supply, internal bus	safe electrical isolation acc. to IEC/EN 60079-11, voltage peak value 375 V
Directive conformity	
Directive 94/9/EC	EN 60079-0 , EN 60079-1
<b>International approvals</b>	
IECEx approval	pending
<b>General information</b>	
System information	The module has to be mounted in appropriate backplanes and housings (FB92**) in Zone 1, 2, 21, 22 or outside hazardous areas (gas or dust). Here, the corresponding EC-Type Examination Certificate has to be observed.

Release date 2012-12-10 11:50 Date of issue 2012-12-10 542154\_eng.xml

## Supplementary information

EC-Type Examination Certificate, Statement of Conformity, Declaration of Conformity, Attestation of Conformity and instructions have to be observed where applicable. For information see [www.pepperl-fuchs.com](http://www.pepperl-fuchs.com).