

Basic series

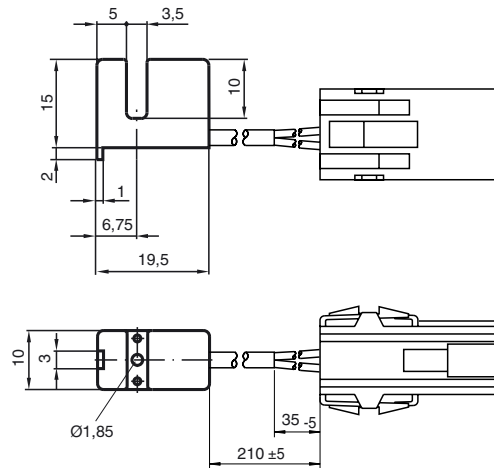

General specifications	
Switching element function	NPN Antivalent
Slot width	3.5 mm
Depth of immersion (lateral)	4.26 ... 5.78 typ. 5 mm
Installation	
Nominal ratings	
Operating voltage U_B	10 ... 30 V
Switching frequency f	0 ... 2000 Hz
Hysteresis H	0.15 ... 0.75
Reverse polarity protection	Protected against reverse polarity
Short-circuit protection	no
Voltage drop U_d	≤ 1 V
Operating current I_L	0 ... 200 mA
No-load supply current I_0	≤ 15 mA
Ambient conditions	
Ambient temperature	-25 ... 70 °C (248 ... 343 K)
Mechanical specifications	
Connection type	210 mm, cable PVC Connector: AMP-No. 207016-1 Contact: AMP-No. 163086-1
Core cross-section	0.14 mm ²
Housing material	Polyamide (PA)
Protection degree	IP67

Connection type:

A / A0

