

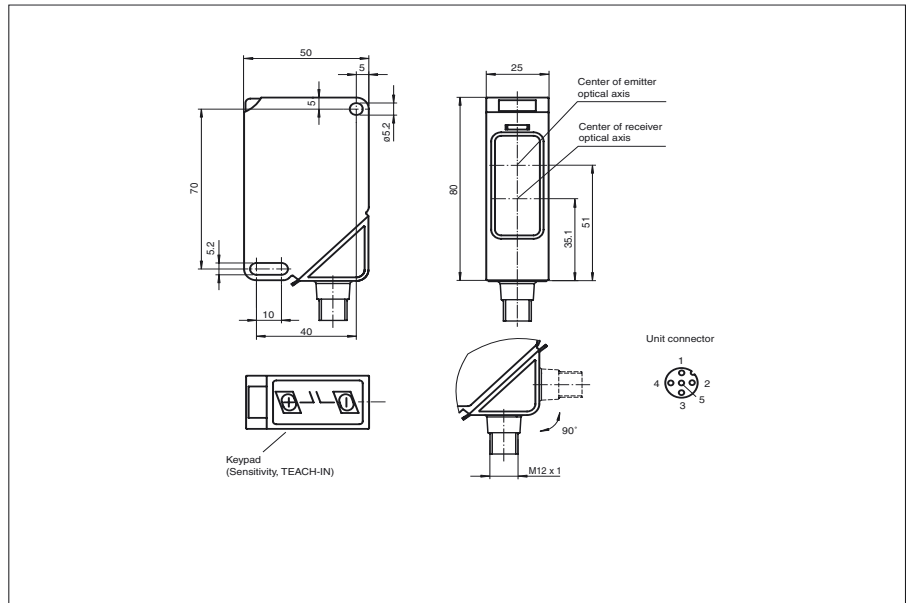

**Dimensions**



**Model Number**

**L27/LV27/47/76a/112**

Thru-beam sensor  
with 5-pin M12 connector, 90° adjustable position

**Features**

- Detection range up to 35 m
- Visible red light
- Pre-fault indication and output (dynamic and static)
- Automatic adjustment of sensitivity per Teach-In
- Detection of partially transparent objects
- Multifunction input
- Parameterisation via optical communication link (e.g. optional time increments)
- Protection degree IP67

**Electrical connection**

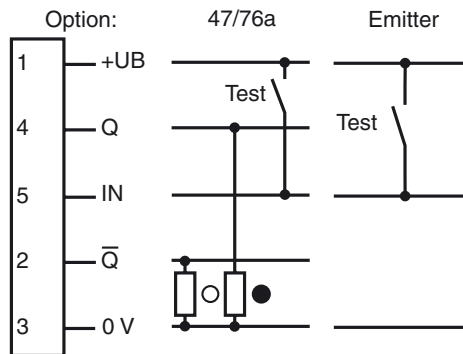

○ = Light on  
● = Dark on

Release date: 2007-09-20 17:00 Date of issue: 2007-09-20 421577\_ENG.xml

## Technical data

### General specifications

Effective detection range	0 ... 35 m
Light source	LED
Approvals	CE
Adjustment range	15 ... 35 m
Reference target	receiver
Light type	red, modulated light
Ambient light limit	10000 Lux

### Indicators/operating means

Operating display	LED green
Function display	TEACH-IN: LED green flashing switching state: LED yellow pre-fault indicator: LED red flashing
Operating elements	membrane keys for setting sensitivity and TEACH-IN

### Electrical specifications

Operating voltage	10 ... 30 V DC
Ripple	10 %
No-load supply current	$I_0 \leq 28 \text{ mA (device)}$
Time delay before availability	$t_v \leq 290 \text{ ms}$

### Input

Test input	inactive: $\leq 3 \text{ V}$ or unwired; active: $\geq 7 \text{ V}$ (emitter)
Control input	inactive: $\leq 3 \text{ V}$ or unwired; active: $\geq 7 \text{ V}$ (receiver)

### Output

Output of the pre-fault indication	pnp, dynamic/static configurable
Switching type	light/dark switching
Signal output	2 switch outputs pnp, parameterisable as - NO/NC (antivalent) - NO and pre-fault indication - NC and pre-fault indication
Switching voltage	max. 30 V DC
Switching current	max. 200 mA
Voltage drop	$U_d \leq 2.5 \text{ V DC}$
Switching frequency	$f \leq 1 \text{ kHz}$
Response time	$\leq 0.6 \text{ ms}$
Timer function	parameterisable

### Standard conformity

Standards	EN 60947-5-2
-----------	--------------

### Ambient conditions

Ambient temperature	-25 ... 70 °C (248 ... 343 K)
Storage temperature	-40 ... 70 °C (233 ... 343 K)

### Mechanical specifications

Protection degree	IP67
Connection	5-pin M12 x 1 connector, 90° adjustable position
Material	
Housing	ABS
Optical face	scratch resistant plastic pane
Mass	emitter: 60 g receiver: 65 g

## Curves/Diagrams

