

**Dimensions**

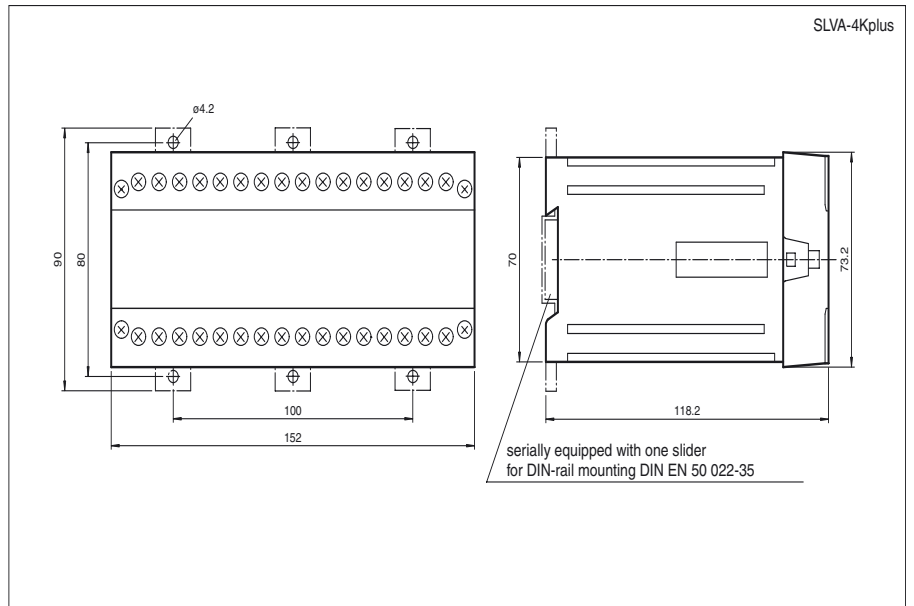

**Model Number**

SLVA-4Kplus-2528 115VAC

**Features**

- Self-monitoring (type 4 according to IEC/EN 61496-1)
- Evaluation device for safety thru-beam sensors SLA, for safety light grids SLP and for 2 channel safety devices (emergency off)
- Operating mode can be selected by means of DIP switches
- Start/Restart disable
- Relay monitor
- Pre-fault indication
- Clearly visible LED functional display
- 7-segment diagnostic display
- Safety outputs OSSD, external status displays OSSD

**Electrical connection**

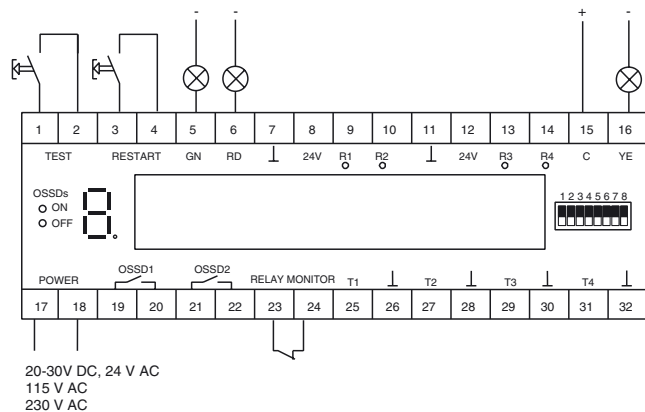

20-30V DC, 24 V AC  
115 V AC  
230 V AC

Release date: 2009-12-14 11:24 Date of issue: 2011-04-15 421023\_ENG.xml

## Technical data

### General specifications

Approvals	TÜV; cNRTLus
Tests	IEC/EN 61496
Safety type according to IEC/EN 61496	4
Marking	CE
Operating mode	Emergency off

### Functional safety related parameters

Safety Integrity Level (SIL)	SIL 3
Performance level (PL)	PL e
Category	Cat. 4
Mission Time (T <sub>M</sub> )	20 a
PFH <sub>d</sub>	1.97 E-9

### Indicators/operating means

Diagnostics display	7-segment display
Function display	LED red: OSSD off LED green: OSSD on LED yellow 4x: Indicator lamp channel 1 ... 4
Pre-fault indication	LED yellow flashing: Indicator lamp channel 1 ... 4
Controls	8 DIP-switches for selection of operating modes

### Electrical specifications

Operating voltage	U <sub>B</sub>	115 V AC +10/-15 %
No-load supply current	I <sub>0</sub>	50 mA
Power consumption	P <sub>0</sub>	13 VA

### Input

Activation current	approx. 1 mA
Activation time	0.03 ... 1 s
Test input	Reset-input for system test

### Output

Safety output	2 relay outputs, force-guided NO-contact
Signal output	Relay contacts for the switching state message of the OSSDs
Switching voltage	20 ... 230 V AC/DC
Switching current	AC: 0.01 ... 2 A DC see diagram of limit load curve
Response time	40 ms

### Ambient conditions

Ambient temperature	0 ... 50 °C (32 ... 122 °F)
Storage temperature	-20 ... 75 °C (-4 ... 167 °F)

### Mechanical specifications

Protection degree	IP20
Connection	Connection terminals, max. conductor cross-sectional area 1.5 mm <sup>2</sup>
Material	
Housing	Polycarbonate/V-0
Mass	900 g

## Operating modes

The mode of operation is adjusted according to the description of the item when the unit leaves the factory. The user can change the mode of operation. After changing the mode of operation, before the system is enabled, a test of the effectiveness of the selected setting must always take place.

You can adjust the modes of operation of the SLVA-4Kplus with the DIP switches. The DIP switches are accessible by removing the transparent covering on the upper side of the analyser unit.

Two switches should each be moved into the same position.

Switch	Position	Mode of operation
1 + 5	OFF	Without startup/restart disable (restart)
	ON	With startup/restart disable (restart)
2 + 6	OFF	Without relay monitor (EDM)
	ON	With relay monitor (EDM)
3 + 7	OFF	Optical barriers on channels 3 and 4
	ON	Emergency off on channels 3 and 4
4 + 8	OFF	Emergency off static
	ON	Emergency off pulsed

If the DIP switches are turned on during operation, the analyser unit switches into secure state (outputs turned off) and the 7-segment displays shows a P. In addition, output 15/16 flashes (ready for startup).

## Indicator lamps and 7-segment diagnostic display

The positions of the indicator lamps of the analyser units are illustrated schematically below. The numeric display indicates the operating and error states of the BWS. In the error state, the decimal point of the 7-segment display flashes. The R1-R4 indicator lamps (yellow) display the receiver status of the light barriers or emergency off circuit that are connected. The OSSDs indicator lamp (ON = green, OFF = red) displays the status of the safety outputs.

LED	Red	OSSD outputs turned off
	Green	OSSD outputs turned on
	Yellow	Indicator lamps for channels (1-4) On = lightbeam free or emergency off circuit on Flashing = light beam free, minimum function reserve not met Off = light beam interrupted or emergency off circuit turned off
7-segment display		Protective field free, OSSD on (running light)
		Protective field interrupted
		Protective field free, OSSD off, ready for startup
		System error
		DIP switch setting incorrect
		Short circuit in transmitter connection
		Error in simultaneity condition for emergency off channel
		Error in an external relay
		DIP switches are turned on

## Diagrams

### Load limit curve of relay OSSD for DC-current

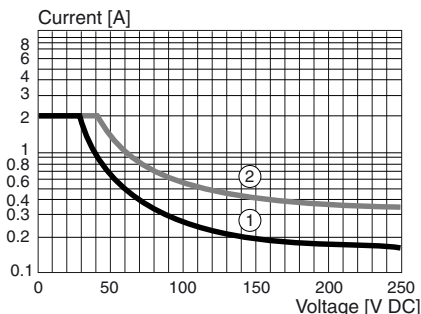

- 1) inductive load, L/R = 40 ms
- 2) ohmic load