



MLV40-54/48/115

Retro-reflective sensor with polarisation filter

MLV40-54/48/115

with 2 m fixed cable



- ◆ Sturdy aluminium housing
- ◆ Scratch-resistant and solvent resistant optical covering made of glass
- ◆ Pre-fault indication
- ◆ Glare protected with polarisation filter

General specifications

Effective detection range	0.1 ... 1000 mm
Reflector distance	100 ... 1000 mm
Threshold detection range	2000 mm (with H60 reflector)
Light source	LED
Approvals	CE, cULus
Light type	red, modulated light
Diameter of the light spot	approx. 100 mm at 1000 mm detection range
Angle of divergence	approx. 4 °
Ambient light limit	80000 Lux

Indicators/operating means

Function display	LED yellow, lights up when light beam is unblocked, flashes when falling short of the stability control
------------------	---

Electrical specifications

Operating voltage	10 ... 30 V DC
Ripple	5 %
No-load supply current I_0	40 mA

Output

Switching type	light/dark switching
Signal output	2 npn antivalent, short-circuit proof, protected against reverse polarity
Switching voltage	max. 30 V DC
Switching current	max. 200 mA
Switching frequency f	500 Hz
Response time	1 ms

Standard conformity

Standards	EN 60947-5-2
-----------	--------------

Ambient conditions

Ambient temperature	-20 ... 60 °C (253 ... 333 K)
Storage temperature	-20 ... 75 °C (253 ... 348 K)

Mechanical specifications

Protection degree	IP65
Connection	fixed cable 2 m
Material	
Housing	aluminium
Optical face	glass
Mass	100 g



MLV40-54/48/115

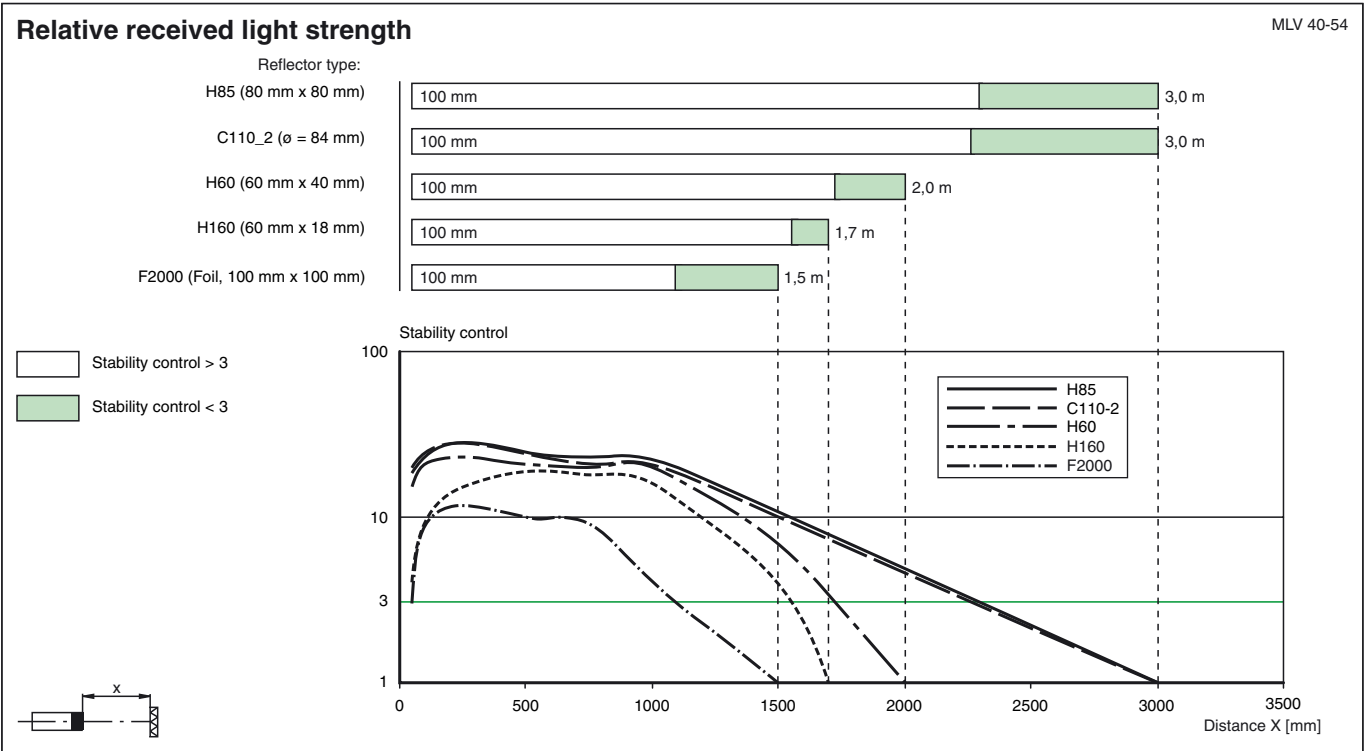
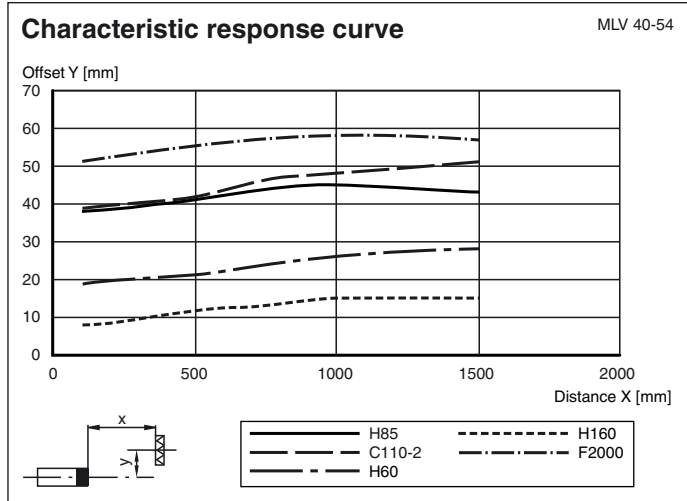

Release date: 2007-01-24 12:10 Date of issue: 2007-01-24 418834_ENG.xml

Dimensions

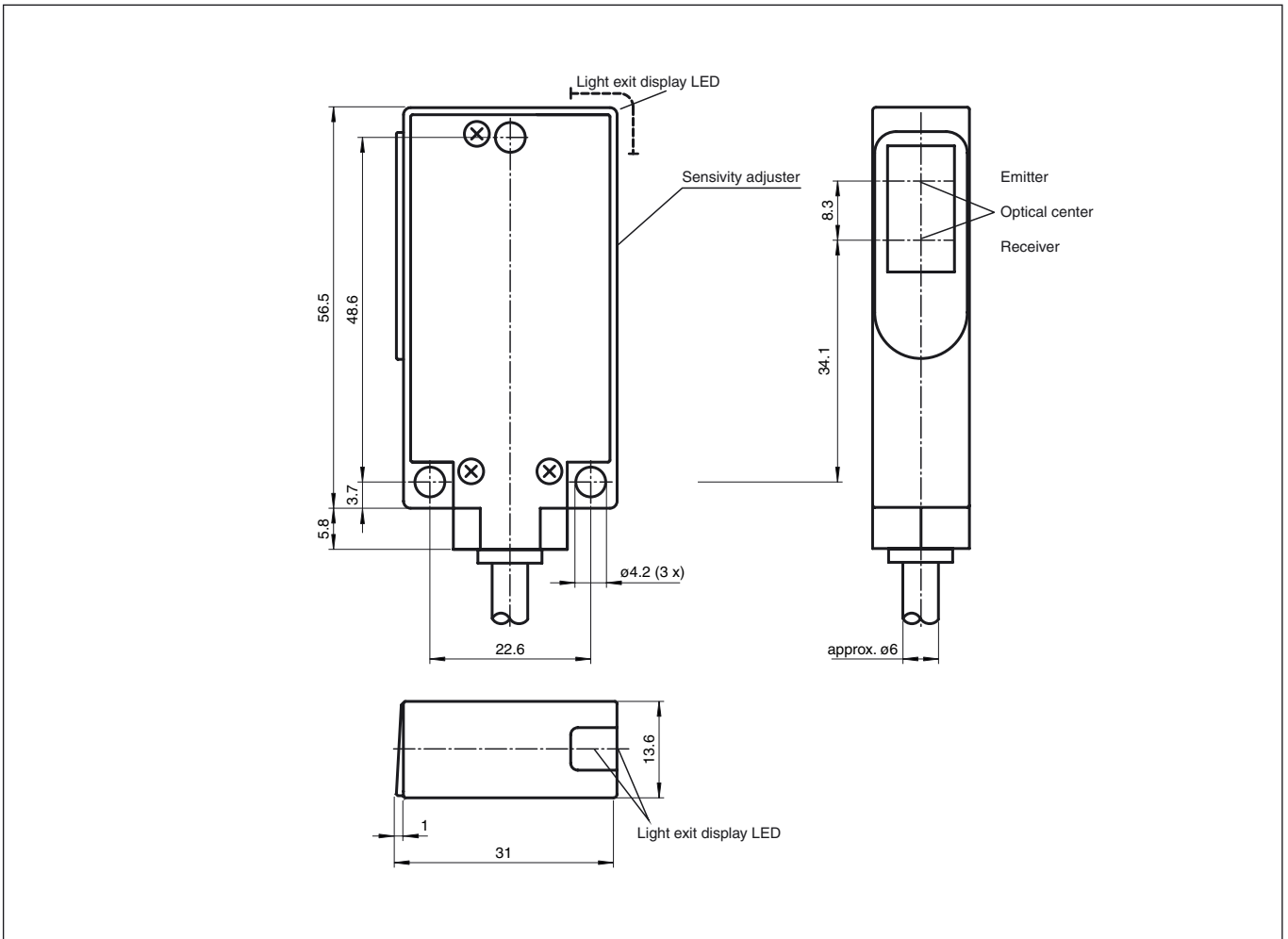

Electrical connection

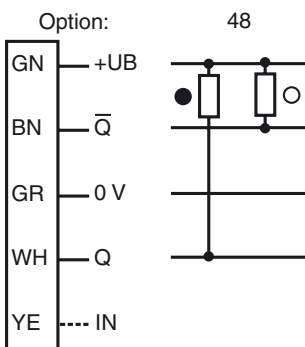

○ = light on, ● = dark on

Release date: 2007-01-24 12:10 Date of issue: 2007-01-24 418834_ENG.xml