



MLV40-6/40b/49/115

Retro-reflective sensor

# MLV40-6/40b/49/115

with 2 m fixed cable



- ◆ Sturdy aluminium housing
- ◆ Scratch-resistant and solvent resistant optical covering made of glass
- ◆ Pre-fault indication

**General specifications**

Effective detection range	0.1 ... 2 m
Reflector distance	100 ... 2000 mm
Threshold detection range	4 m (with H60 reflector)
Light source	IRED
Approvals	CE, cULus
Light type	infrared, modulated light
Diameter of the light spot	100 mm at 2000 mm detection range
Angle of divergence	approx. 4 °
Ambient light limit	80000 Lux

**Indicators/operating means**

Function display	LED yellow, lights up when light beam is unblocked, flashes when falling short of the stability control
------------------	---

**Electrical specifications**

Operating voltage	10 ... 30 V DC
Ripple	5 %
No-load supply current $I_0$	40 mA

**Output**

Switching type	light/dark switching
Signal output	1 pnp and 1 npn short-circuit proof, protected against reverse polarity
Switching voltage	max. 30 V DC
Switching current	max. 200 mA
Switching frequency f	500 Hz
Response time	1 ms

**Standard conformity**

Standards	EN 60947-5-2
-----------	--------------

**Ambient conditions**

Ambient temperature	-20 ... 60 °C (253 ... 333 K)
Storage temperature	-20 ... 75 °C (253 ... 348 K)

**Mechanical specifications**

Protection degree	IP65
Connection	fixed cable 2 m
Material	
Housing	aluminium
Optical face	glass
Mass	100 g



# MLV40-6/40b/49/115

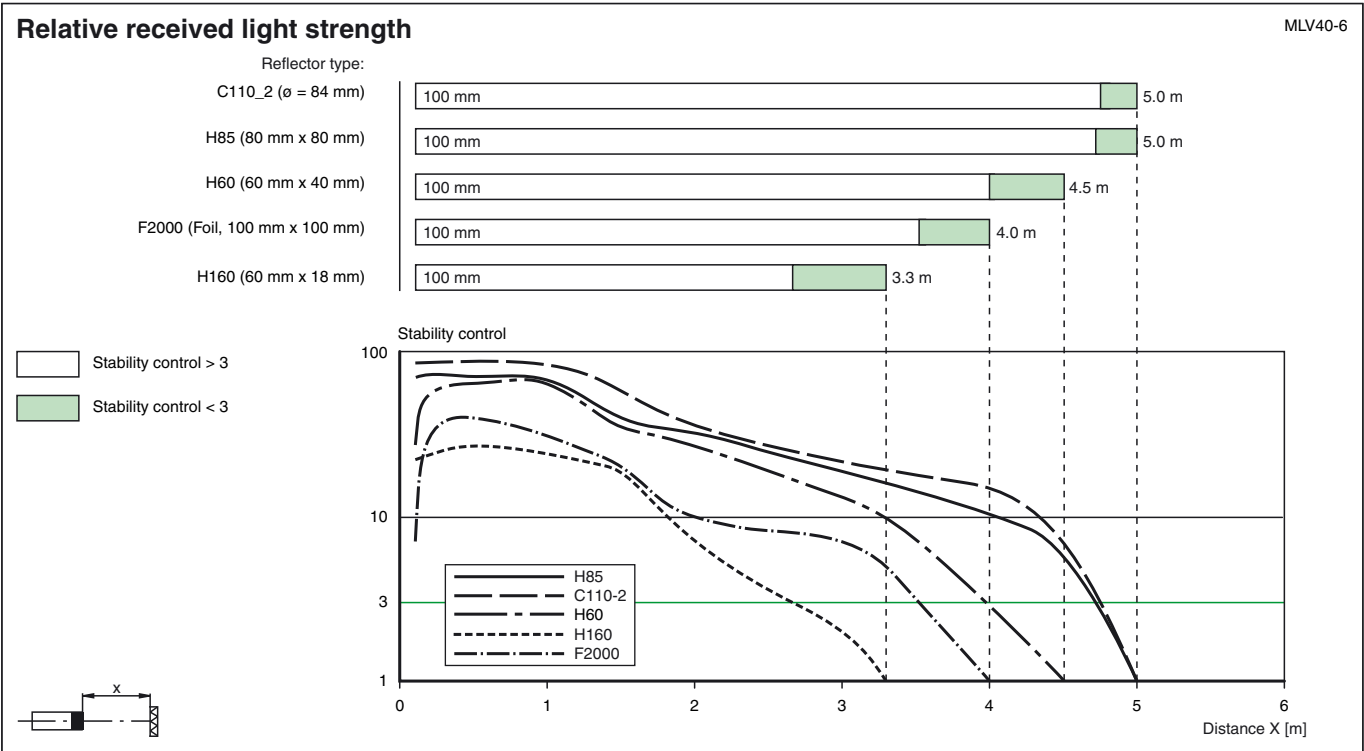
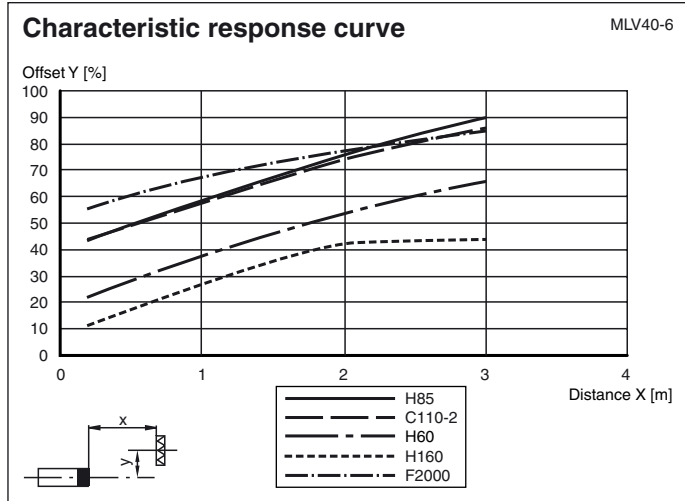

Dimensions

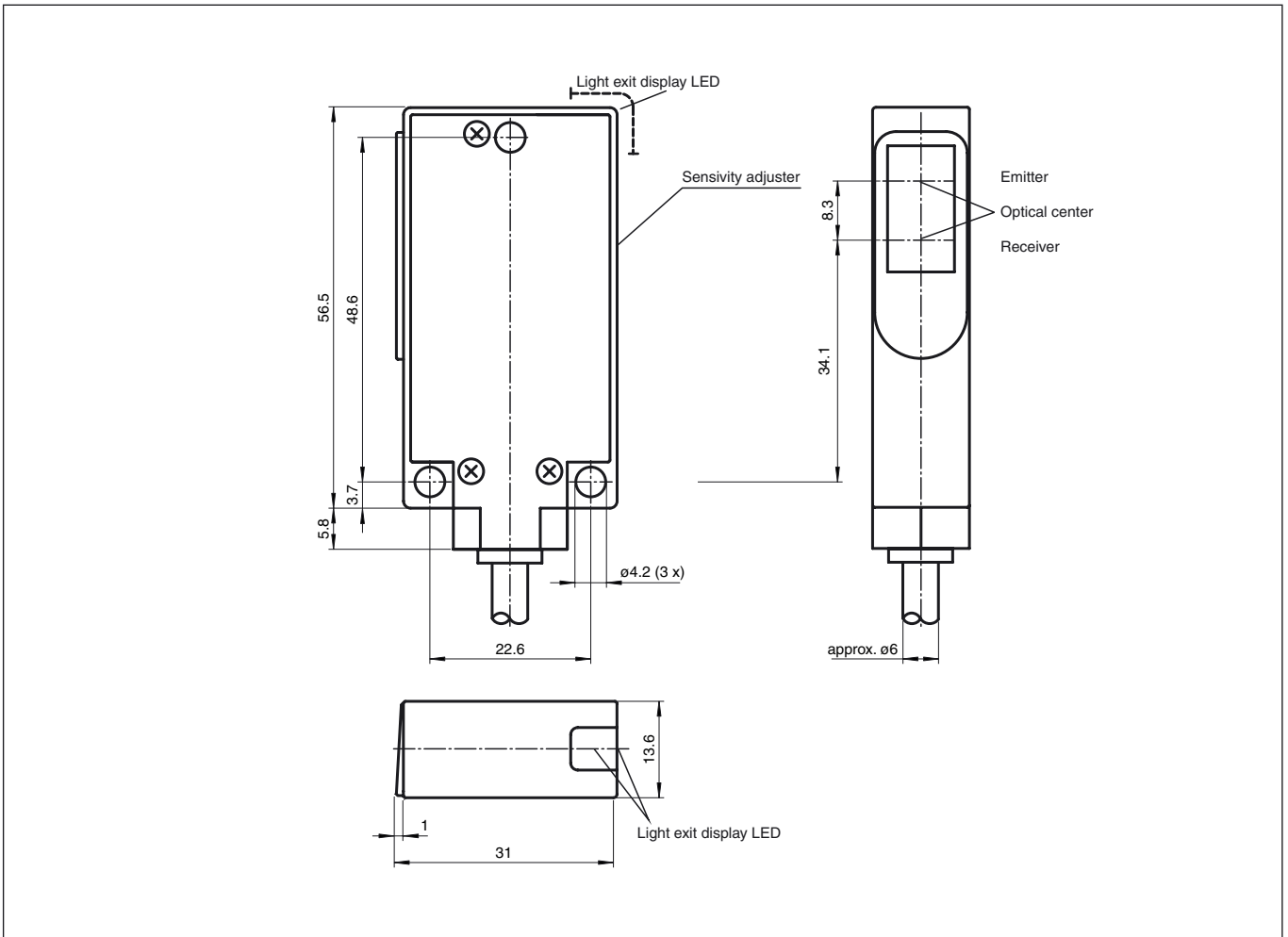

Electrical connection

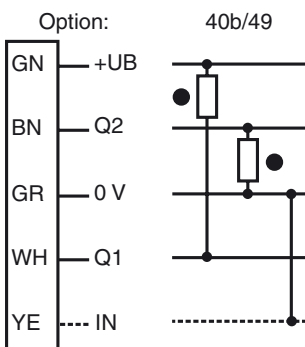

○ = light on, ● = dark on

Release date: 2007-01-24 12:09 Date of issue: 2007-01-24 418815\_ENG.xml