

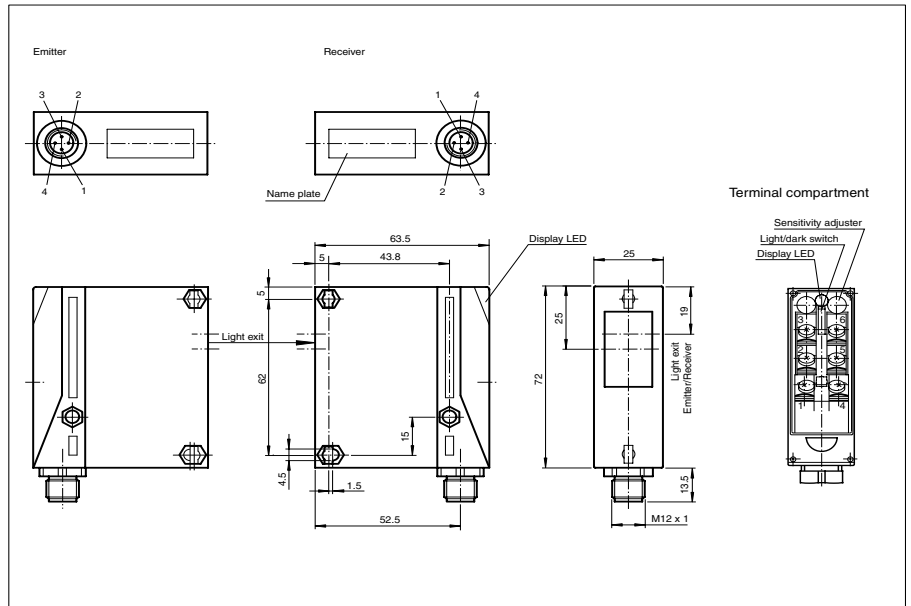

Dimensions



Model Number

L25/LV25/35/47/92

Thru-beam sensor
with M12, 4-pin metal connector

Features

- Detection range up to 45 m
- Compact design
- Sensitivity adjuster and light-/dark switch
- Pre-fault indication
- Test input

Electrical connection

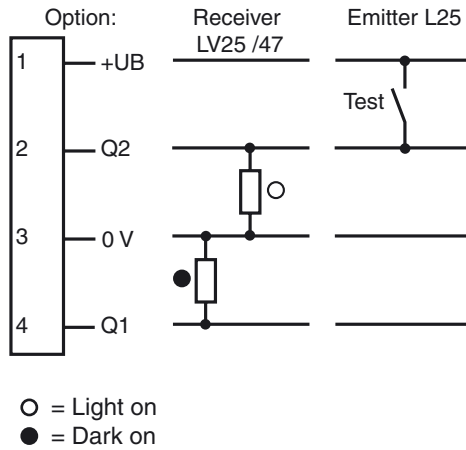

Release date: 2007-09-21 11:12 Date of issue: 2007-09-21 418501_ENG.xml

Technical data

General specifications

Effective detection range	0 ... 30 m
Threshold detection range	45 m
Light source	IREL
Approvals	CE, cULus
Obstacle size	18 mm
Light type	infrared, modulated light
Diameter of the light spot	350 mm at a distance of 10 m
Angle of divergence	Emitter: approx. 2 °, receiver: approx. 4 °
Ambient light limit	60000 Lux

Indicators/operating means

Function display	LED green, lights up when light beam is free/flashes when falling short of the stability control
Operating elements	Light/dark switch (receiver)
Operating elements	sensitivity adjuster (emitter)

Electrical specifications

Operating voltage	10 ... 30 V DC
Ripple	10 %
No-load supply current	I_0 40 mA (device)

Input

Test input	Emitter deactivation
------------	----------------------

Output

Switching type	Light/dark ON, switchable
Signal output	2 pnp, antivalent, short-circuit proof, protected against reverse polarity
Switching voltage	30 V DC
Switching current	max. 200 mA
Switching frequency	f 250 Hz
Response time	2 ms

Standard conformity

Standards	EN 60947-5-2
-----------	--------------

Ambient conditions

Ambient temperature	-20 ... 60 °C (253 ... 333 K)
Storage temperature	-20 ... 75 °C (253 ... 348 K)

Mechanical specifications

Protection degree	IP65
Connection	M12 connector, 4-pin
Material	
Housing	Terluran GV15
Optical face	glass
Mass	90 g (device)

Curves/Diagrams

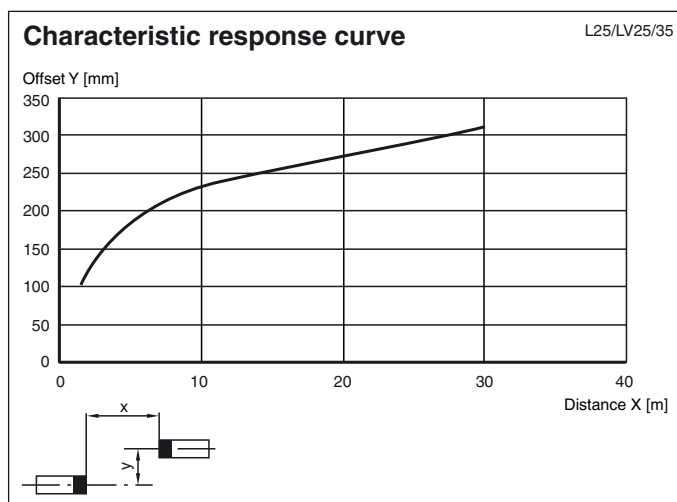

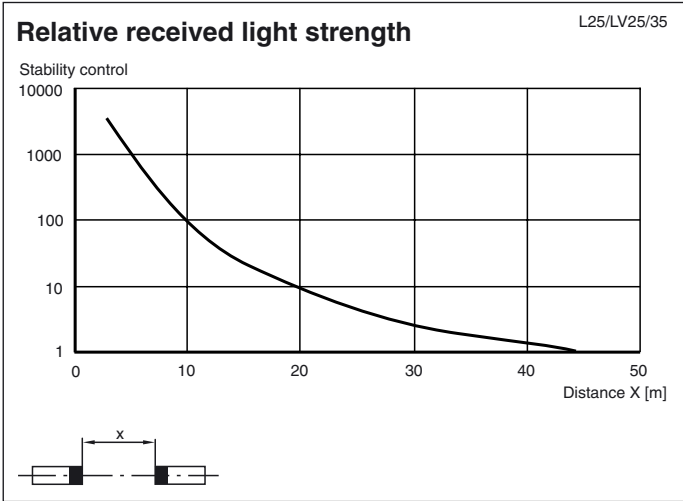

Release date: 2007-09-21 11:12 Date of issue: 2007-09-21 418501_ENG.xml