



Model Number

PIR20/31 sw

Passive infrared motion sensor with terminal compartment

Features

- Door activation sensor
- One of the smallest sensors for person detection
- Reliable detection through change in the thermal image from +/- 0.5 °C
- Accurate and seamless field adjustment through aperture and zoom function
- Function only in case of movement

Product information

The PIR20 passive infrared scanner enables problem-free detection of people. It detects movement as soon as the temperature differential between an object and its environment is greater than ± 0.5°C. The detection range can be accurately set by means of zoom adjustment and lens apertures. The PIR20 detects people approaching as a door.

Release date: 2012-05-30 16:42 Date of issue: 2012-08-03 417999_eng.xml

Dimensions

Mounting dimensions with mounting bracket

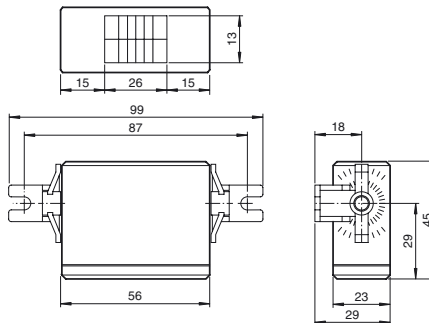

Mounting dimensions for swivel

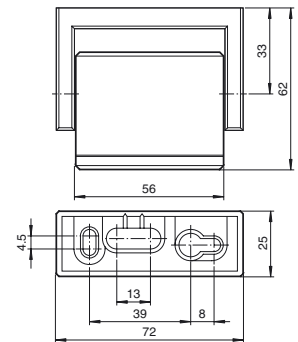

Electrical connection

Option:

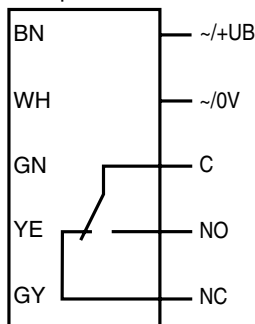

Indicators/operating means

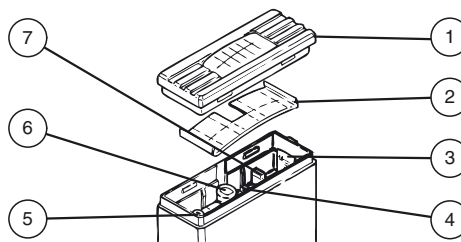

1	Housing cover
2	Lens cover
3	Zooming scale
4	Zooming screw
5	Sensitivity adjuster
6	LED
7	Switch active/passive

Technical data**General specifications**

Effective detection range	max. 12 m (frontal)
Detection field	max. 1800 mm x 2600 mm for a mounting height of 2500 mm

Indicators/operating means

Operating display	LED green
Function display	LED red: illuminates upon detection
Controls	Zoom screw for adjusting the detection field, sensitivity adjustment, changeover switch, active/passive

Electrical specifications

Operating voltage	U_B	12 ... 24 V AC / 12 ... 30 V DC
No-load supply current	I_0	approx. 15 mA
Power consumption	P_0	approx. 350 mW at 24 V

Output

Switching type	Output active/passive, programmable	
Signal output	Relay, 1 alternator	
Switching voltage	48 V AC/DC	
Switching current	1 A	
Switching power	max. 30 W / 60 VA	
De-energized delay	t_{off}	0.5 s (preset)

Ambient conditions

Ambient temperature	-20 ... 60 °C (-4 ... 140 °F)
---------------------	-------------------------------

Mechanical specifications

Mounting height	recommended: max. 3.5 m
Protection degree	IP52
Connection	screw terminals, removable
Material	
Housing	black ABS
Optical face	plastic lens
Mass	approx. 40 g

Approvals and certificates

CE conformity	yes
---------------	-----

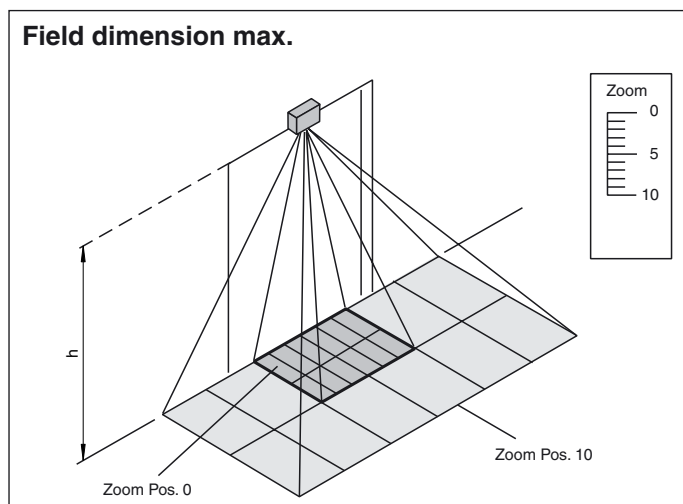
Curves/Diagrams**Typical applications**

- Detection of movement by people
- Opening impulse sensor for people at automatic doors
- Elevator entrance area monitoring

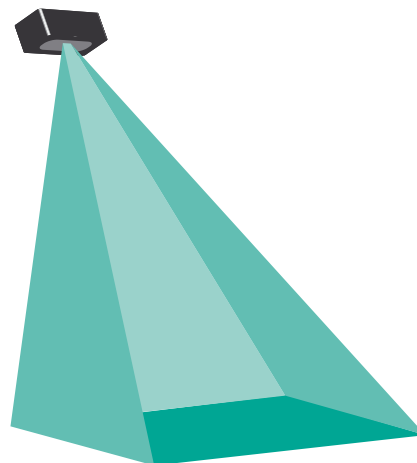
Detection area**Accessories****Wetterschutzhaube PIR 20**

Weather hood for series PIR20

Flush Mounting PIR20

Flush-mounted frame for sensors in the PIR20

AIR20/PIR20 Weather Cap

All-weather hood for AIR20 and PIR20 series sensors

Other suitable accessories can be found at www.pepperl-fuchs.com

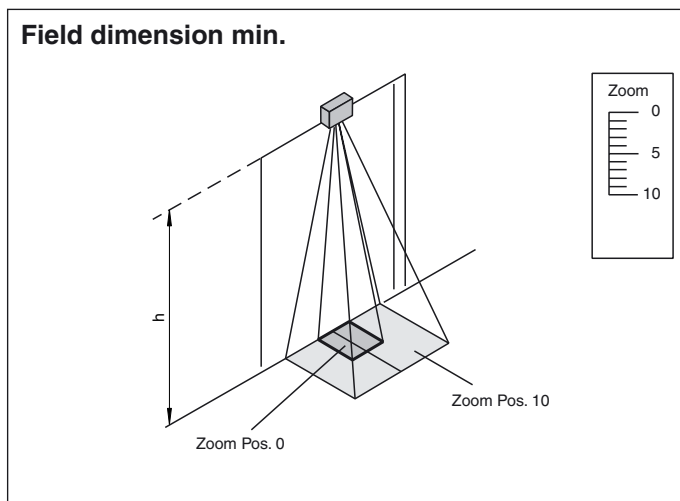

Operating principle

The passive infrared scanner functions differently to most optical sensors — as a passive device. A passive device is not equipped with a transmitter element, but does feature a receiver element. The receiver reacts to heat emission in the form of infrared light transmitted by the human body. This infrared light is detected by a multi-part lens system (fresnel lens), which means that the intended detection range can be fully covered by the receiver. Within 20 seconds of switching on the sensor, the receiver measures and stores the infrared image identified. A switching signal is transmitted when two conditions have been met:

1. The temperature of the object to be detected deviates from the ambient temperature by at least $\pm 0.5^{\circ}\text{C}$.
2. The object to be detected moves at a speed of at least 100 mm/sec.