



### Model Number

#### REF-H50AF

Reflector, rectangular 60 mm x 51 mm, mounting holes, fixing strap

### Features

- Anti-fog coating
- Mounting holes for simple installation

### Application

Fogging of the reflectors is prevented by using a surface coating. Fogging takes place when moisture condenses on the surface. Fine, microscopically small water droplets form. This effect occurs particularly in areas with varying temperature, such as can happen with gate systems, bus and tram doors in winter and cold stores. The surface of the anti-misting reflectors is made in such a way that in the presence of moisture the surface is wetted and the formation of droplets prevented. If the reflectors are used in very cold areas under 0 °C, such as cold stores, it is possible that fogging from contact with warm air is prevented, but the surface of the reflector covered in water can ice over and the reflector no longer works properly. It is therefore a good idea to check whether there is a danger of icing. If this is the case, alternative, heated reflectors can be used.

### Dimensions

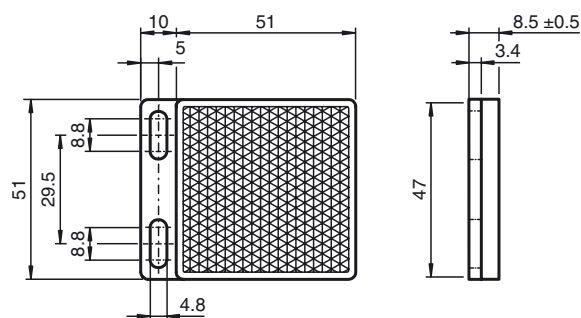

### Technical data

#### General specifications

Construction type rectangular

#### Ambient conditions

Ambient temperature -40 ... 70 °C (-40 ... 158 °F)

#### Mechanical specifications

Material PMMA  
 Dimensions 60 mm x 51 mm x 8.5 mm  
 Mounting mounting holes