



**Model Number**

NBB15-U10-E2-25M

**Features**

- 15 mm embeddable
- 4 LEDs indicator for 360° visibility

**Connection**

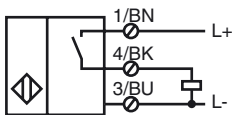

**Accessories**

- MH 04-2681F**  
Mounting aid for VariKont, +U1+ and +U9\*
- MHW 01**  
Modular mounting bracket

**Dimensions**

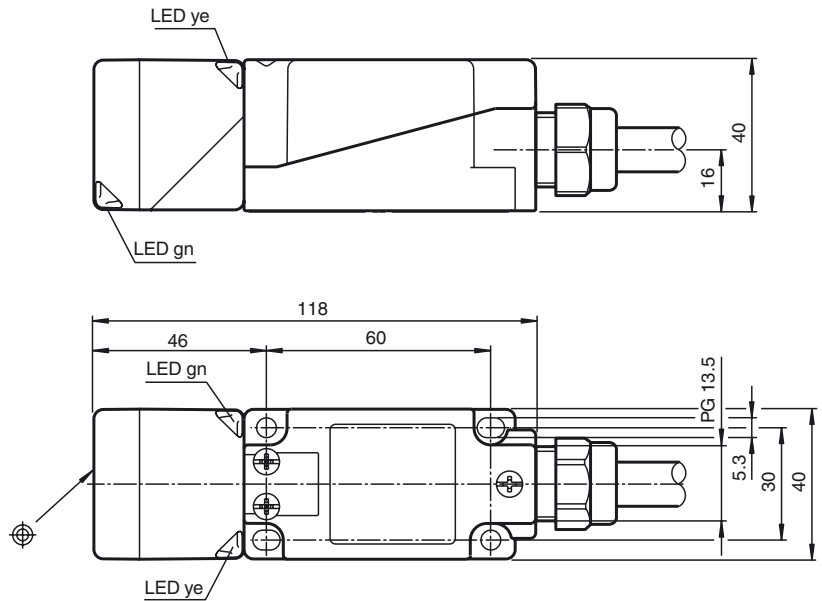

**Technical Data**

**General specifications**

Switching element function	PNP	NO
Rated operating distance	$s_n$	15 mm
Installation	embeddable	
Output polarity	DC	
Assured operating distance	$s_a$	0 ... 12.15 mm
Reduction factor $r_{A1}$	0.33	
Reduction factor $r_{Cu}$	0.31	
Reduction factor $r_{304}$	0.74	
Reduction factor $r_{Brass}$	0.41	

**Nominal ratings**

Operating voltage	$U_B$	10 ... 30 V
Switching frequency	$f$	0 ... 200 Hz
Hysteresis	$H$	typ. 5 %
Reverse polarity protected	reverse polarity protected	
Short-circuit protection	pulsing	
Voltage drop	$U_d$	$\leq 2$ V
Operating current	$I_L$	0 ... 200 mA
Off-state current	$I_r$	0 ... 0.5 mA typ. 0.01 mA
No-load supply current	$I_0$	$\leq 20$ mA
Operating voltage display	LED, green	
Indication of the switching state	LED, yellow	

**Functional safety related parameters**

MTTF <sub>d</sub>	1460 a
Mission Time (T <sub>M</sub> )	20 a
Diagnostic Coverage (DC)	0 %

**Ambient conditions**

Ambient temperature	-25 ... 85 °C (-13 ... 185 °F)
---------------------	--------------------------------

**Mechanical specifications**

Connection type	cable PUR , 25 m
Core cross-section	3 x 0.5 mm <sup>2</sup>
Housing material	PA/metal with epoxy powder coating
Sensing face	PA
Housing base	plastic
Protection degree	IP68 / IP69K
Mass	225 g
Note	Tightening torque: 1.8 Nm (housing) Tightening torque: 1.0 Nm (Screw terminal)

**Compliance with standards and directives**

Standard conformity	
Standards	EN 60947-5-2:2007 IEC 60947-5-2:2007

**Approvals and certificates**

UL approval	cULus Listed, General Purpose
CSA approval	cCSAus Listed, General Purpose
CCC approval	Products with a maximum operating voltage of $\leq 36$ V do not bear a CCC marking because they do not require approval.

Release date: 2012-03-02 16:47 Date of issue: 2012-03-02 240275\_eng.xml