



### Model Number

**OMH-SLCT-05**

Mounting bracket including adjustment

### Features

- Mounting bracket
- Large swivel range  $-7^\circ \dots +110^\circ$
- Sturdy construction
- Simple and fast mounting

### Dimensions

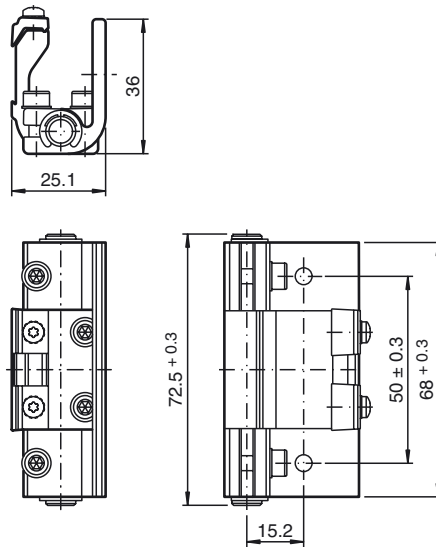

### Technical data

#### General specifications

Setting angle	$-7 \dots 110^\circ$
---------------	----------------------

#### Mechanical specifications

Material	aluminum
Mass	approx. 87 g

#### Suitable series

Safety Series	SLCT SLCS
---------------	--------------

