



Model Number

PSE4-RUB-04

Sensor strip for safety edges from the PSE4 series

Features

- Rubber profile
- For mounting to ALU mounting strip PSE4-ALU
- Simple to customize to application
- Versions up to 10 m in length are available
- Component of PSE4 modular system

Accessories

PSE4-ALU-01

Extruded aluminum mounting strip for safety edges from the PSE4 series

PSE4-ALU-02

Extruded aluminum mounting strip for safety edges from the PSE4 series

PSE4-SL-01

Safety photoelectric sensor for the PSE4 series

PSE4-SC-01

Safety control unit from the PSE4 series

Dimensions

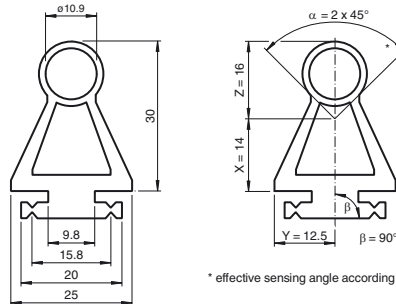

* effective sensing angle according to EN 1760-2

Technical data

General specifications

Length 10 m

Ambient conditions

Ambient temperature -30 ... 100 °C (-22 ... 212 °F)
 Environmental resistance Excellent

Mechanical specifications

Material EPDM (ethylene propylene diene rubber)
 Mass approx. 3000 g

Notes

The PSE 4 module is comprised of the following components:

Safety thru-beam sensors PSE4-SL:

The emitter and receiver housings are fully encapsulated to provide maximum protection against environmental influences such as water, dust and moisture and achieve degree of protection IP 68.

Sensor strips PSE4-RUB and PSE4-ROI:

The sensor strip has a two chamber design. The emitter and receiver are housed in the round top chamber. When the sensor strip is actuated, the optical channel is interrupted and the safety contacts on the control unit open. When actuation occurs in the end area, the emitter and receiver are pushed into the lower chamber to ensure that the light beam is broken. However, the force required is extremely high and the end areas become inactive as specified in EN 1760-2.

Safety control unit PSE4-SC:

The signal from the emitter/receiver system is evaluated as specified in EN ISO /IEC 61496-1 according to control category 4.

Aluminum rails PSE4-ALU:

Aluminum mounting rails are available in different lengths.

Operating principle

The emitter transmits pulses of infrared light, which are detected by the receiver. When the emitter light is detected, the receiver turns off the emitter via a control input. The "optical emission" stops. The receiver also detects this status and the emitter is then switched on again after a specified time. This coupling generates a dynamic signal sent to a buffer. The evaluation analyzes the charge state of the buffer.

Any errors in the emitter/receiver system affect the optical or electrical signal, which results in the absence of a dynamic signal.

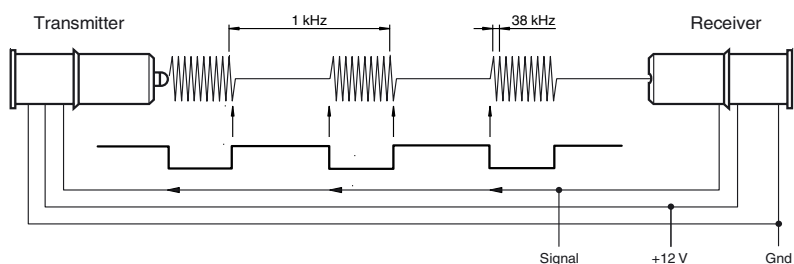

Release date: 2011-06-20 09:30 Date of issue: 2011-07-12 233904_eng.xml

Note:

Only fully fitted safety edges comply with the examination certificate for the PSE4 series.

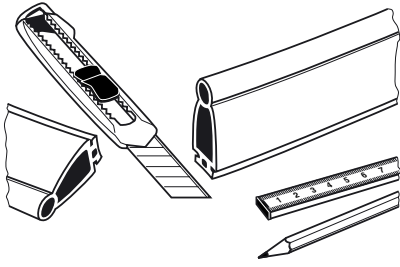
Mounting or replacing the sensors

Sensor strip PSE4-RUB-XX or PSE4-ROI-XX and accompanying aluminum mounting strip
Cut PSE4-ALU-XX to the required length.

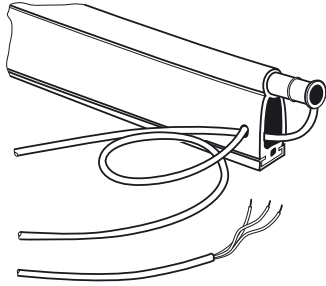

Slide the emitter and receiver into the upper chamber.
Guide the emitter cable through the lower chamber to the receiver side.

Application

The complete PSE4 safety edge system consists of a control unit, sensors, a rubber sensor strip and an optional aluminum mounting strip. The system has been tested within a temperature range of 5 °C to 55 °C according to EN 1760-2 and is suitable for finger protection.

The control unit evaluates the signal from the sensors and was designed for installation in a control cabinet. The safety contact on the control unit opens when the sensor strip is deformed. The complete system fulfills performance level e, cat. 4 according to EN ISO 13849-1.