



Model Number

NCN3-F31-B3B-V1-K

Valve positioner and valve control module

Features

- Direct mounting on standard actuators
- Nominal sensing range 3 mm by V2A target
- A/B slave with extended addressing possibility for up to 62 slaves
- Mode of operation, programmable
- Protection degree IP67
- Communication monitoring, turn-off
- Lead breakage and short-circuit monitoring of the valve

Connection

B3B-V1-K

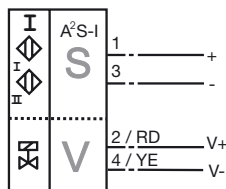

Pinout

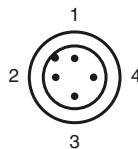

Accessories

- BT65A**
Activator for F31 series
- BT65X**
Activator for F31 series
- BT115A**
Activator for F31 series
- BT115X**
Activator for F31 series
- BT65B**
Activator for F31 series
- BT115B**
Activator for F31 series
- V1-W-2M-PUR**
Cable socket, M12, 4-pin, PUR cable
- V1-G-2M-PUR**
Cable socket, M12, 4-pin, PUR cable

Dimensions

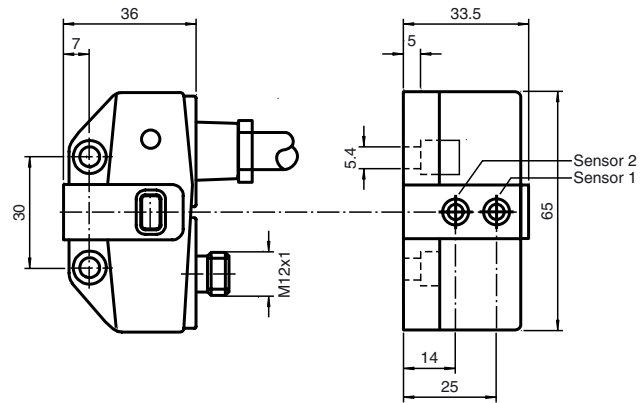

Drawing without actuator

Technical Data

General specifications

Switching element function		programmable
Rated operating distance	s_n	3 mm
Installation		embeddable mountable
Output polarity		AS-Interface
Assured operating distance	s_a	0 ... 2.43 mm
Reduction factor r_{Al}		0.5
Reduction factor r_{Cu}		0.45
Reduction factor r_{303}		1
Reduction factor r_{St37}		1.2
Slave type		A/B slave
AS-Interface specification		V3.0
Required master specification		$\geq V2.1$

Nominal ratings

Operating voltage	U_B	26.5 ... 31.9 V via AS-i bus system
Switching frequency	f	0 ... 100 Hz
No-load supply current	I_0	≤ 35 mA

Functional safety related parameters

MTTF _d		842 a
Mission Time (T_M)		20 a
Diagnostic Coverage (DC)		0 %

Indicators/operating means

LED PWR		AS-Interface voltage; LED green
LED IN		switching state (input); LED yellow
LED OUT		binary LED yellow/red yellow: switching state red: lead breakage/short-circuit

Electrical specifications

Rated operational voltage	U_e	26.5 ... 31.6 V from AS-Interface
Rated operational current	I_e	100 mA

Ambient conditions

Ambient temperature		-25 ... 70 °C (-13 ... 158 °F)
---------------------	--	--------------------------------

Mechanical specifications

Connection (system side)		connector M12 x 1, 4-pin
Connection (valve side)		0.5 m, PVC cable
Core cross-section (valve side)		0.75 mm ²
Protection degree		IP67
Material		
Housing		PBT
Note		valve voltage limited to 26,4 V max.; valve power 2,5 W max.

Compliance with standards and directives

Standard conformity		
Electromagnetic compatibility		EN 50295:1999-10
Standards		EN 60947-5-2:2007 IEC 60947-5-2:2007

Approvals and certificates

UL approval		cULus Listed, General Purpose
CSA approval		cCSAus Listed, General Purpose
CCC approval		Products with a maximum operating voltage of ≤ 36 V do not bear a CCC marking because they do not require approval.

Release date: 2011-07-28 17:14 Date of issue: 2011-07-28 22:6322_eng.xml

Supplementary information

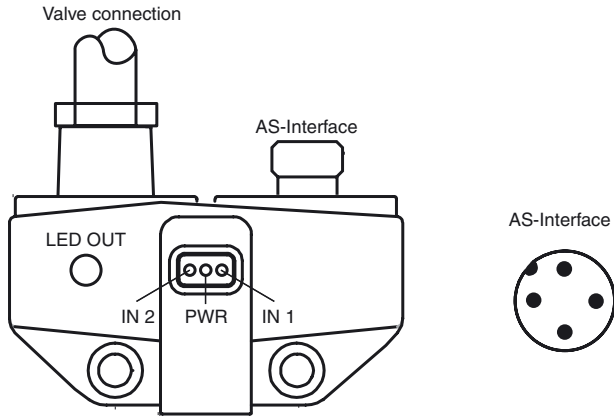

Programming Instructions

Address 00 preset, alterable via Busmaster or programming units
 IO-code D
 ID-code A
 ID1-code 7
 ID2-code E

Data bit

Bit	Function
D0	valve status (0=valve OFF, 1=valve ON)
D1	valve fault ¹⁾ (0=lead breakage/short circuit; 1=no fault)
D2	switch output sensor 1 ²⁾ (0=damped; 1=undamped)
D3	switch output sensor 2 ²⁾ (0=damped; 1=undamped)

Parameter bit

Bit	Function
P0	Watchdog (0=inactive; 1=active) ³⁾
P1	switching element function sensor II ⁴⁾ (0=NO; 1= NC)
P2	switching element function sensor I ⁴⁾ (0=NO; 1= NC)
P3	not used

- 1) Verification only with actuated valve (D0=1)
- 2) Applies to NC function (P2/P3=1; preset), with NO function (P2/P3=0) reversed characteristics
- 3) Watchdog active: valve voltage drops with the occurrence of an AS-I communication fault
- 4) Default setting: NC

Release date: 2011-07-28 17:14 Date of issue: 2011-07-28 226322_eng.xml

Installation hint

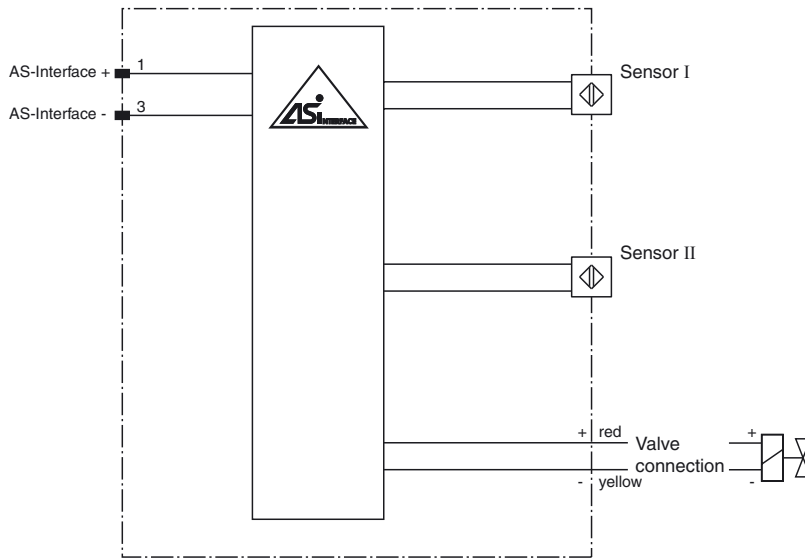

Programming Instructions

Address	00 preset, alterable via Busmaster or programming units
IO-code	D
ID-code	A
ID1-code	7
ID2-code	E

Data bit

Bit	Function
D0	valve status (0=valve OFF, 1=valve ON)
D1	valve fault ¹⁾ (0=lead breakage/short circuit; 1=no fault)
D2	switch output sensor 1 ²⁾ (0=damped; 1=undamped)
D3	switch output sensor 2 ²⁾ (0=damped; 1=undamped)

Parameter bit

Bit	Function
P0	Watchdog (0=inactive; 1=active) ³⁾
P1	switching element function sensor II ⁴⁾ 0=NO; 1= NC)
P2	switching element function sensor I ⁴⁾ 0=NO; 1= NC)
P3	not used

¹⁾ Verification only with actuated valve (D0=1)

²⁾ Applies to NC function (P2/P3=1; preset), with NO function (P2/P3=0) reversed characteristics

³⁾ Watchdog active: valve voltage drops with the occurrence of an AS-I communication fault

⁴⁾ Default setting: NC

The NCN3-F31-B3B-V1-K is an inductive dual sensor used to indicate the valve positioning of actuators. The dual sensor is mounted directly on the actuator using two screws. Additional adjustment is not necessary.

A cable connection on the sensor is used directly for the valve controls. The NCN3-F31-B3B-V1-K is connected via a M12x1 screw fixing to the bus line. This makes it possible to transmit both the switch signal for the valve and the messages of the sensors via AS-Interface. They are both powered directly through the bus cable. Moreover, the valve is monitored for lead breakage and short circuit. The D1 data bit monitors the fault signal.

The sensors can be programmed as normally closed and normally open contacts (parameter bit P1 and P2). If there are no communications on the bus cable, the valve is automatically de-energised. This communication monitoring can be turned off via the parameter bit P0.



The current switching states are displayed by means of yellow LEDs.

Release date: 2011-07-28 17:14 Date of issue: 2011-07-28 22:6322_eng.xml