



Model Number

NCN3-F31-N5-V18-V1

Features

- Direct mounting on standard actuators
- Compact and stable housing
- Fixed setting
- EC-Type Examination Certificate TÜV99 ATEX 1479X
- 2:1 transfer method

Connection

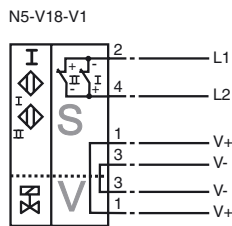

Pinout

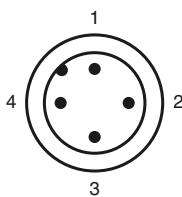

Wire colors in accordance with EN 60947-5-2

1	BN	(brown)
2	WH	(white)
3	BU	(blue)
4	BK	(black)

Accessories

VMA-2+P/Z2-0,3M-PVC-V1-W-Y
Valve connector, Form A on M12, 2+PE, LED, Z diode, PVC cable

VMB-2+P/Z2-0,3M-PVC-V1-W-Y
Valve connector, Form B on M12, 2+PE, LED, Z diode, PUR cable

VMC-2+P/Z2-0,3M-PVC-V1-W-Y
Valve connector, model C on M12, 2 + PE, LED, zener diode, PVC cable

Dimensions

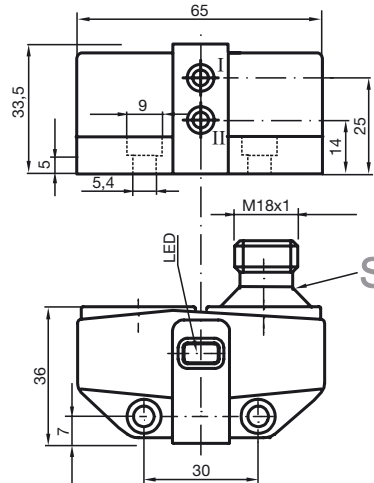

Technical Data

General specifications

Switching element function	DC	Dual NC
Rated operating distance	s_n	3 mm
Installation		flush mountable
Output polarity		NAMUR
Assured operating distance	s_a	0 ... 2.4 mm
Reduction factor r_{Al}		0.35
Reduction factor r_{Cu}		0.3
Reduction factor r_{304}		0.75
Reduction factor r_{St37}		1
Reduction factor r_{Brass}		0.45

Nominal ratings

Nominal voltage	U_o	8 V
Switching frequency	f	0 ... 3 kHz
Hysteresis	H	typ. 5 %
Short-circuit protection		yes
Suitable for 2:1 technology		yes, Reverse polarity protection diode not required
Current consumption		
Measuring plate not detected		≥ 3 mA
Measuring plate detected		≤ 1 mA
Indication of the switching state		LED, yellow
Valve status indication		LED, yellow

Ambient conditions

Ambient temperature -25 ... 100 °C (-13 ... 212 °F)

Note:

Under the same product name but with a different part no., this product has a predecessor with a restricted temperature range (up to +70 °C).

The temperature range specified here (up to +100°C) only applies to sensors with part no. 2239**.

Storage temperature -40 ... 100 °C (-40 ... 212 °F)

Mechanical specifications

Connection (system side)	V18 connector
Connection (valve side)	V1 connector
Housing material	PBT
Sensing face	PBT
Protection degree	IP67

General information

Use in the hazardous area	see instruction manuals
Category	1G; 2G; 3G

Compliance with standards and directives

Standard conformity	
NAMUR	EN 60947-5-6:2000 IEC 60947-5-6:1999
Electromagnetic compatibility	NE 21:2007
Standards	EN 60947-5-2:2007 IEC 60947-5-2:2007

Approvals and certificates

UL approval	cULus Listed, General Purpose
CSA approval	cCSAus Listed, General Purpose
CCC approval	Products with a maximum operating voltage of ≤ 36 V do not bear a CCC marking because they do not require approval.

Release date: 2012-07-09 10:26 Date of issue: 2012-08-07 223964_eng.xml

ATEX 1G

Instruction

Manual electrical apparatus for hazardous areas

Device category 1G

for use in hazardous areas with gas, vapour and mist

Directive conformity

94/9/EG

Standard conformity

EN 60079-0:2009, EN 60079-11:2007, EN 60079-26:2007

Ignition protection "Intrinsic safety"

Use is restricted to the following stated conditions

CE symbol

 0102

Ex-identification

 II 1G Ex ia IIC T6

EC-Type Examination Certificate

TÜV 99 ATEX 1479 X

Appropriate type

NC..-F31-N5..

Effective internal capacitance C_i

≤ 200 nF A cable length of 10 m is considered.

The value is applicable for the sensor circuit.

Effective internal inductance L_i

≤ 200 μH A cable length of 10 m is considered.

The value is applicable for the sensor circuit.

General

The apparatus has to be operated according to the appropriate data in the data sheet and in this instruction manual.

The EC-Type Examination Certificate has to be observed. The special conditions must be adhered to!

Directive 94/9/EG and hence also EC-Type Examination Certificates apply in general only to the use of electrical apparatus under atmospheric conditions.

The use in ambient temperatures of > 60 °C was tested with regard to hot surfaces by the mentioned certification authority.

If the equipment is not used under atmospheric conditions, a reduction of the permissible minimum ignition energies may have to be taken into consideration.

Highest permissible ambient temperature

The temperature ranges, according to temperature class, are given in the EC-Type Examination Certificate. **The maximum permissible ambient temperature of the data sheet must be noted, in addition, the lower of the two values must be maintained.** Note: Use the temperature table for category 1 !!! The 20 % reduction in accordance with EN 1127-1:2007 has already been accounted for in the temperature table for category 1.

Installation, Commissioning

Laws and/or regulations and standards governing the use or intended usage goal must be observed.

The intrinsic safety is only assured in connection with an appropriate related apparatus and according to the proof of intrinsic safety.

The associated apparatus must satisfy the requirements of category ia.

Due to the possible danger of ignition, which can arise due to faults and/or transient currents in the equipotential bonding system, galvanic isolation of the power supply and signal circuit is preferable. Associated apparatus without electrical isolation must only be used if the appropriate requirements of IEC 60079-14 are met.

Maintenance

No changes can be made to apparatus, which are operated in hazardous areas. Repairs to these apparatus are not possible.

Special conditions

Protection from mechanical danger

When used in the temperature range below -20 °C the sensor should be protected from knocks by the provision of an additional housing.

Electrostatic charging

When used in group IIC non-permissible electrostatic charges should be avoided on the plastic housing parts.

ATEX 2G

Instruction

Device category 2G

Directive conformity

Standard conformity

CE symbol

Ex-identification

EC-Type Examination Certificate

Appropriate type

Effective internal capacitance C_i Effective internal inductance L_i

General

Highest permissible ambient temperature

Installation, Commissioning

Maintenance

Special conditions

Protection from mechanical danger

Manual electrical apparatus for hazardous areas

for use in hazardous areas with gas, vapour and mist

94/9/EG

EN 60079-0:2009, EN 60079-11:2007

Ignition protection "Intrinsic safety"

Use is restricted to the following stated conditions

 0102

 II 1G Ex ia IIC T6

TÜV 99 ATEX 1479 X

NC..-F31.-N5...

 $\leq 200 \text{ nF}$; a cable length of 10 m is considered. The value is applicable for the sensor circuit.

 $\leq 200 \text{ }\mu\text{H}$; a cable length of 10 m is considered. The value is applicable for the sensor circuit.

The apparatus has to be operated according to the appropriate data in the data sheet and in this instruction manual. The EC-Type Examination Certificate has to be observed. The special conditions must be adhered to!

Directive 94/9/EG and hence also EC-Type Examination Certificates apply in general only to the use of electrical apparatus under atmospheric conditions.

The use in ambient temperatures of $> 60 \text{ }^\circ\text{C}$ was tested with regard to hot surfaces by the mentioned certification authority.

If the equipment is not used under atmospheric conditions, a reduction of the permissible minimum ignition energies may have to be taken into consideration.

The temperature ranges, according to temperature class, are given in the EC-Type Examination Certificate. **The maximum permissible ambient temperature of the data sheet must be noted, in addition, the lower of the two values must be maintained.**

Laws and/or regulations and standards governing the use or intended usage goal must be observed. The intrinsic safety is only assured in connection with an appropriate related apparatus and according to the proof of intrinsic safety.

No changes can be made to apparatus, which are operated in hazardous areas. Repairs to these apparatus are not possible.

When used in the temperature range below $-20 \text{ }^\circ\text{C}$ the sensor should be protected from knocks by the provision of an additional housing.

ATEX 3G (ic)

Instruction

Device category 3G (ic)

Directive conformity

Standard conformity

CE symbol

Ex-identification

Effective internal capacitance C_i Effective internal inductance L_i

General

Installation, Commissioning

Maintenance

Special conditionsMaximum permissible ambient temperature T_{Umax} at $U_i = 20$ Vfor $P_i=34$ mW, $I_i=25$ mA, T6for $P_i=34$ mW, $I_i=25$ mA, T5for $P_i=34$ mW, $I_i=25$ mA, T4-T1for $P_i=64$ mW, $I_i=25$ mA, T6for $P_i=64$ mW, $I_i=25$ mA, T5for $P_i=64$ mW, $I_i=25$ mA, T4-T1for $P_i=169$ mW, $I_i=52$ mA, T6for $P_i=169$ mW, $I_i=52$ mA, T5for $P_i=169$ mW, $I_i=52$ mA, T4-T1

Maximum values of the valve circuit

Protection from mechanical danger

Connection parts

Manual electrical apparatus for hazardous areas

for use in hazardous areas with gas, vapour and mist

94/9/EG

EN 60079-11:2007 Ignition protection category "ic"

Use is restricted to the following stated conditions

CE 0102

II 3G Ex ic IIC T6 X

 ≤ 200 nF ; A cable length of 10 m is considered.
The value is applicable for the sensor circuit. ≤ 200 μ H ; A cable length of 10 m is considered.
The value is applicable for the sensor circuit.The apparatus has to be operated according to the appropriate data in the data sheet and in this instruction manual. The data stated in the data sheet are restricted by this operating instruction!
The special conditions must be observed!Laws and/or regulations and standards governing the use or intended usage goal must be observed. The sensor must only be operated with energy-limited circuits, which satisfy the requirements of IEC 60079-11. The explosion group depends on the connected, energy-limited power supply circuits.
The maximum values of the connected, energy-limited valve circuits, must be observed.No changes can be made to apparatus, which are operated in hazardous areas.
Repairs to these apparatus are not possible.

Each sensor circuit can be operated with the stated maximum values and with simultaneous operation of the valve circuits.

70 °C (158 °F)

70 °C (158 °F)

70 °C (158 °F)

70 °C (158 °F)

70 °C (158 °F)

70 °C (158 °F)

67 °C (152.6 °F)

70 °C (158 °F)

70 °C (158 °F)

 $U_i = 32$ V; $I_i = 240$ mA; $C_i = 10$ nF; $L_i = 20$ μ H

The values are applicable to each valve circuit. A cable length of 10 m is taken into account.

The sensor must not be mechanically damaged.

When used in the temperature range below -20 °C the sensor should be protected from knocks by the provision of an additional housing.

The connection parts are to be installed, such that a minimum protection class of IP20 is achieved, in accordance with IEC 60529.