



Model Number

SBL-8-H-900-IR-SL-V-Z-3535

Background suppression sensor with 4-pin, M12 x 1 connector and fixed cable with 4-pin, M12 socket

Features

- Background suppression sensor for roller conveyors
- For installation between the rollers on a roller conveyor
- Very small black-white difference
- Adjustable detection range
- Can be connected in series
- ON/Off delay adjustable
- 3 in 1: Diffuse mode sensor, pneumatic valve and integrated control logic

Product information

Sensors of the SBL series are used to easily control material flow on roller conveyors in material handling and other branches.

The SBL series is a precise background suppression sensor according to the 3 element method. The sensor features superior background suppression and a very good ambient light immunity. Material and transport container of all colors and opacities are reliably detected.

The special design allows the sensor to be mounted between the rollers of a roller conveyor or any other conveying unit. Mounting between the rollers is easy and protects the sensor.

Dimensions

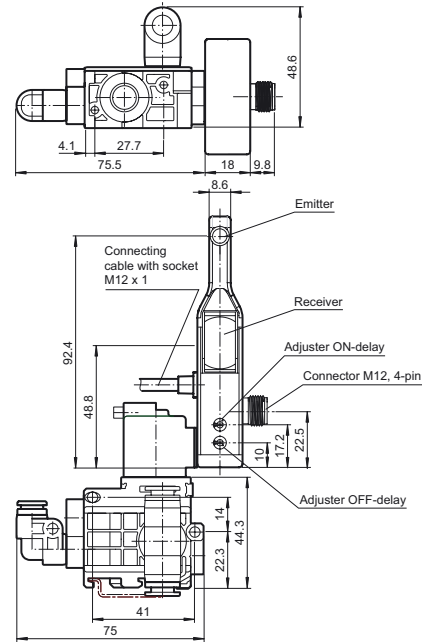
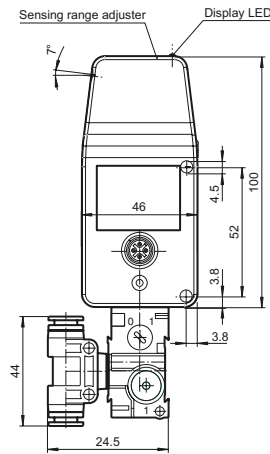

Electrical connection

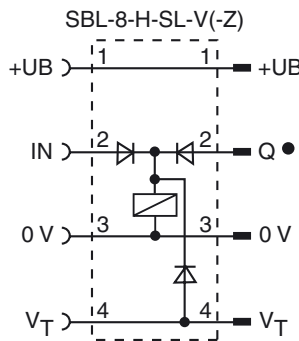

○ = Light on
● = Dark on

Pinout

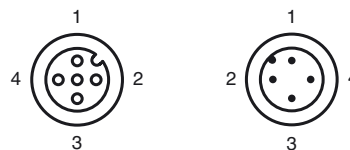

Indicators/operating means

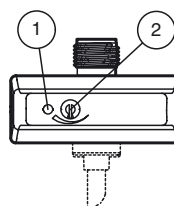

| | | |
|---|------------------------|--------|
| 1 | Signal display | yellow |
| 2 | Sensing range adjuster | |

Release date: 2011-12-21 16:32 Date of issue: 2012-02-17 223826_eng.xml

Subject to modifications without notice

Pepper+Fuchs Group
www.pepperl-fuchs.com

USA: +1 330 486 0001
fa-info@us.pepperl-fuchs.com

Germany: +49 621 776-4411
fa-info@pepperl-fuchs.com

Copyright Pepper+Fuchs
Singapore: +65 6779 9091
fa-info@sg.pepperl-fuchs.com

Technical data**General specifications**

| | |
|-----------------------------------|--|
| Detection range | 40 ... 900 mm |
| Detection range min. | 40 ... 340 mm |
| Detection range max. | 40 ... 900 mm |
| Adjustment range | 340 ... 900 mm |
| Reference target | standard white 200 mm x 200 mm |
| Light source | IREL |
| Light type | modulated infrared light , 880 nm |
| Black/White difference (6 %/90 %) | < 10 % |
| Diameter of the light spot | approx. 60 mm at detection range 900 mm |
| Cascadability | At 20°C: max. 38 sensors per line |
| Ambient light limit | continuous light 30000 Lux , Fluorescent lamp 5000 Lux |

Functional safety related parameters

| | |
|--------------------------------|--------|
| MTTF _d | 1100 a |
| Mission Time (T _M) | 20 a |
| Diagnostic Coverage (DC) | 0 % |

Indicators/operating means

| | |
|------------------|---|
| Function display | LED yellow: lights when object is detected |
| Controls | Detection range adjuster |
| Controls | Adjuster for switch-off delay and switch-on delay |

Electrical specifications

| | | |
|------------------------|----------------|----------------|
| Operating voltage | U _B | 24 V DC ± 20 % |
| Ripple | | max. 10 % |
| No-load supply current | I ₀ | max. 115 mA |

Output

| | | |
|---------------------|--|--------|
| Switching type | dark on | |
| Signal output | 1 PNP, short-circuit protected, reverse polarity protected | |
| Switching voltage | max. 30 V DC | |
| Switching current | max. 200 mA | |
| Switching frequency | f | 100 Hz |
| Response time | 5 ms | |
| On-delay | 0 ... 2000 ms | |
| Off-delay | 0 ... 2000 ms | |
| Pneumatic output | 3/2 way valve | |
| Type of valve | currentless opened | |
| Operating pressure | 2 ... 8 bar (29 ... 116 psi) | |
| Medium | air | |

Ambient conditions

| | |
|---------------------|--------------------------------|
| Ambient temperature | -15 ... 50 °C (5 ... 122 °F) |
| Storage temperature | -30 ... 60 °C (-22 ... 140 °F) |

Mechanical specifications

| | |
|-------------------|---|
| Protection degree | IP65 |
| Connection | connector M12 x 1, 4-pin ; Connecting cable with Socket, straight M12 x 1 ; Length: 1200 mm |
| Material | |
| Housing | plastic |
| Optical face | plastic lens |
| Mass | approx. 200 g |

Compliance with standards and directives

| | |
|-----------------------------|--|
| Directive conformity | EMC Directive 2004/108/EC |
| Standard conformity | |
| Product standard | EN 60947-5-2:2007 IEC 60947-5-2:2007 |
| Shock and impact resistance | IEC / EN 60068. half-sine, 40 g in each X, Y and Z directions |
| Vibration resistance | IEC / EN 60068-2-6. Sinus. 10 -1000 Hz, 10 g in each X, Y and Z directions |

Approvals and certificates

| | |
|--------------|--|
| UL approval | cULus Listed, Class 2 Power Source, Type 1 enclosure |
| CCC approval | Products with a maximum operating voltage of ≤36 V do not bear a CCC marking because they do not require approval. |

Accessories**OMH-SBL-01**

Mounting bracket for sensors of SBL series

V1-G-2M-PVC

Cable socket, M12, 4-pin, PVC cable

V1-G-5M-PVC

Cable socket, M12, 4-pin, PVC cable

V1-W-2M-PUR

Cable socket, M12, 4-pin, PUR cable

V1-W-5M-PUR

Cable socket, M12, 4-pin, PUR cable

V1S-TEE-V1/V1S

T-Distributor, M12 connector to M12 socket/connector

Schraubendreher 0,5 x 3,0 mm

Screwdriver

Additional accessories can be found in the Internet.

Curves/Diagrams

Difference in detection distance

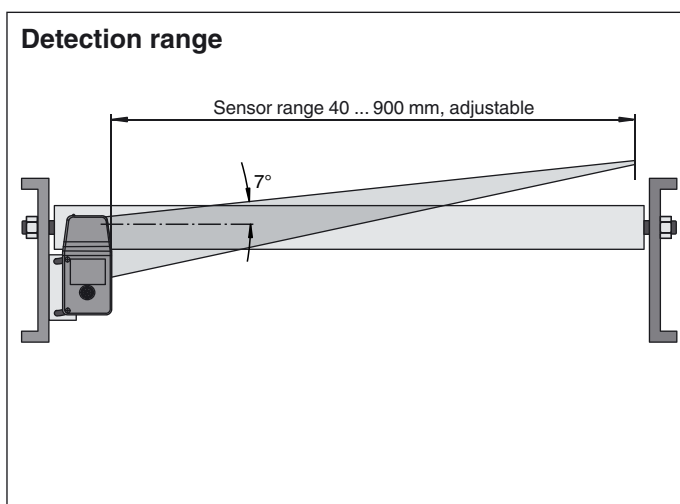
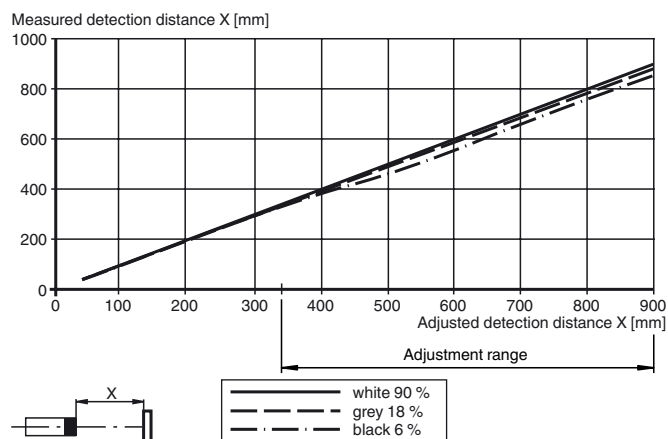

Options:

Sensors with the **version -V** are equipped with a solenoid valve and can directly control a 3/2 way pneumatic actuator, without any-interaction of an external system controlling unit (PLC). As soon as conveyed goods are detected, the diffuse mode sensor gives an electrical-signal to the pneumatic solenoid valve, which is then activated.

Sensors with the control logic **option -SL-(V)** allows up to 50 diffuse mode sensors to be connected-to each other (data and power), depending on the current consumption of sensor and solenoid valve. An additional supply power and data bus cable is used to interconnect the sensors with control logic option -SL. All necessary functions for controlling the material flow of conveyed goods are supported, such as: single feed, single release, slug release, external motor and solenoid valve control. It is also possible to energize the valves of all sensors included in the cascade by slug release (VT). To do this, apply the positive supply voltage (+UB) on the input VT of the first sensor.

Sensors with timing **function -Z** features the adjustment of the ON- and OFF delay of the output independently. This optimizes control of the solenoid valve. A zero pressure accumulation of the conveyed goods can be realized with application of time ON- and OFF delay of the output. The ON- and OFF delay to control the switching of the solenoid valve may be adjusted between 0 and 2 seconds.

Additional power supply between every 20 to 25 sensors can be realized by the use of the power in feed junction V1S-TEE-V1/V1S in combination with a cable V1-G-...-PVC. This features to practically connect any number of SBL sensors in series. Attention should be paid to the maximum rated current of the cable and the connectors which usually is max. I = 4 A. For more details on the maximum rated current of single components, please refer to our datasheet values. For the electrical supply of the sensors the country specific standards have to be considered.

Note:

Use a screwdriver to adjust the sensing range. We strongly recommend to use the screwdriver given in the accessories section.