



## Model Number

NBB20-L2-A2-V1-M

## Features

- 20 mm flush
- e1-Type approval
- Extended temperature range - 40 ... +85 °C
- 4 LEDs indicator for 360° visibility

## Connection

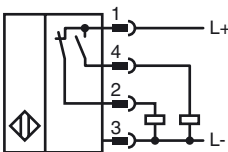

## Accessories

### V1-G

4-pin, M12 female field-attachable connector

### V1-W

4-pin, M12 female field-attachable connector

### V1-G-2M-PUR

Cable socket, M12, 4-pin, PUR cable

### V1-W-2M-PUR

Cable socket, M12, 4-pin, PUR cable

### MHW 01

Modular mounting bracket

### V1-M20-80

Receptacles, M12/M20; plastic version

## Dimensions

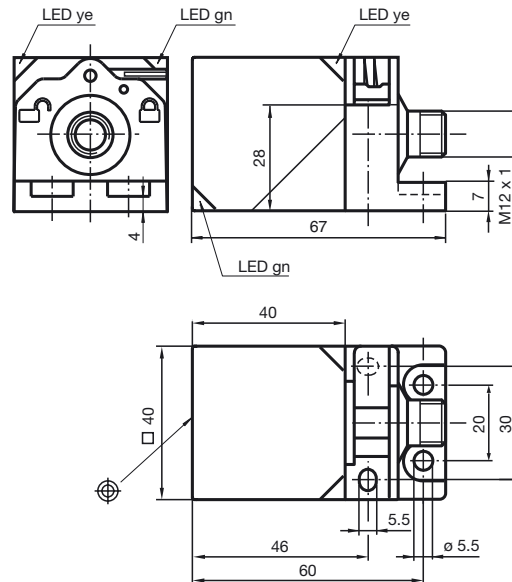

## Technical Data

### General specifications

Switching element function		PNP	NO/NC
Rated operating distance	$s_n$	20 mm	
Installation		flush	
Output polarity		DC	
Assured operating distance	$s_a$	0 ... 16.2 mm	
Reduction factor $r_{Al}$		0.34	
Reduction factor $r_{Cu}$		0.32	
Reduction factor $r_{304}$		0.77	
Reduction factor $r_{St37}$		1	
Reduction factor $r_{Brass}$		0.43	

### Nominal ratings

Operating voltage	$U_B$	10 ... 60 V DC
Switching frequency	$f$	0 ... 200 Hz
Hysteresis	$H$	typ. 5 %
Reverse polarity protected		reverse polarity protected
Short-circuit protection		pulsing
Voltage drop	$U_d$	$\leq 2$ V
Operating current	$I_L$	0 ... 200 mA
Off-state current	$I_r$	0 ... 0.5 mA
No-load supply current	$I_0$	$\leq 20$ mA
Operating voltage display		LED, green
Indication of the switching state		LED, yellow

### Functional safety related parameters

MTTF <sub>d</sub>	695 a
Mission Time (T <sub>M</sub> )	20 a
Diagnostic Coverage (DC)	0 %

### Ambient conditions

Ambient temperature	-40 ... 85 °C (-40 ... 185 °F)
---------------------	--------------------------------

### Mechanical specifications

Connection type	Device connector M12 x 1, 4-pin
Housing material	PA-GF35
Sensing face	PA-GF35
Protection degree	IP69K
Mass	130 g

### Compliance with standards and directives

Standard conformity	
Standards	EN 60947-5-2:2007 IEC 60947-5-2:2007

### Approvals and certificates

UL approval	cULus Listed, General Purpose
CSA approval	cCSAus Listed, General Purpose
e1 Type approval	2006/28/EG

**Installation hint**

Emitted interference and interference immunity in accordance with motor vehicle directive 2006/28/EG (e1 Type approval)  
 Interference immunity in accordance with DIN ISO 11452-2: 30 V/m  
 Frequency band 20 MHz up to 2 GHz

Mains-borne interference in accordance with ISO 7637-2: Pulse

	1	2a	2b	3a	3b	4	5
Severity level	III	III	III	III	III	III	IV
Failure criterion	C	A	C	A	A	A	C

EN 61000-4-2:	CD: 8 kV / AD: 15 kV
Severity level	IV IV
EN 61000-4-3:	30 V/m (80...2500 MHz)
Severity level	IV
EN 61000-4-4:	2 kV
Severity level	III
EN 61000-4-6:	10 V (0.01...80 MHz)
Severity level	III
EN 55011:	Class A

Release date: 2012-07-12 08:55 Date of issue: 2012-07-12 223317\_eng.xml