



**Model Number**

**RST41-INT-4428**

Remission scanner  
with 7-pin flange connector

**Features**

- Remission scanner with large depth of focus
- High switching frequency for the detection of fast moving objects
- Adjustable timer functions
- Protection degree IP64

**Dimensions**

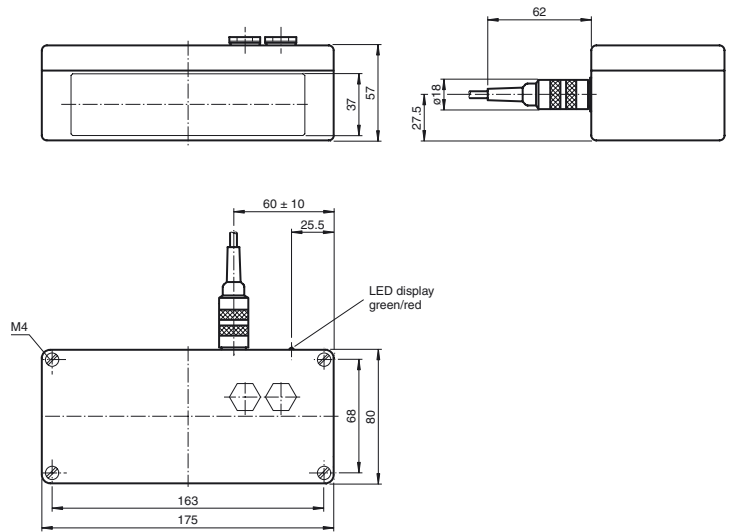

**Electrical connection**

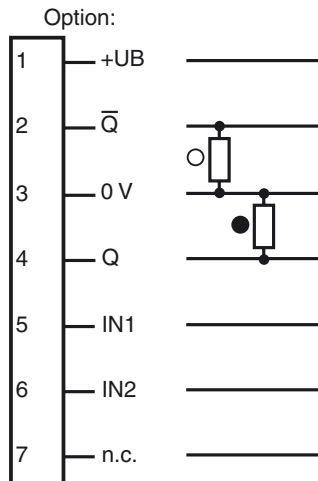

○ = Light on  
● = Dark on

Release date: 2009-08-25 11:07 Date of issue: 2011-01-26 220844\_ENG.xml

## Technical data

### General specifications

Sensor range	40 mm
Light source	IRED
Light type	modulated infrared light
Light spot representation	approx. 20 mm x 70 mm
Approvals	CE
Angle of divergence	$\pm 10^\circ$
Resolution	0.2 mm up to 20 mm step height

### Indicators/operating means

Function display	LED red/green red: no edge green: edge detected
------------------	---

### Electrical specifications

Operating voltage	$U_B$	24 V DC
Ripple		$\pm 10\%$
No-load supply current	$I_0$	approx. 250 mA

### Input

Function input	Pin 5: step pulse input Pin 6: reset input
----------------	---

### Output

Switching type	light/dark on
Signal output	2 PNP, complementary, short-circuit protected, open collectors
Switching voltage	24 V DC
Switching current	200 mA
Switching frequency	f 1000 Hz
Response time	0.15 ms

### Standard conformity

Standards	EN 60947-5-2
-----------	--------------

### Ambient conditions

Ambient temperature	0 ... 50 °C (32 ... 122 °F)
Storage temperature	-20 ... 75 °C (-4 ... 167 °F)

### Mechanical specifications

Protection degree	IP64
Connection	7-pin, T3477 flange connector
Material	
Housing	lacquer-coated aluminum
Optical face	glass
Mass	approx. 600 g

### Approvals and certificates

CCC approval	Products with a maximum operating voltage of $\leq 36$ V do not bear a CCC marking because they do not require approval.
--------------	--

## Curves/Diagrams

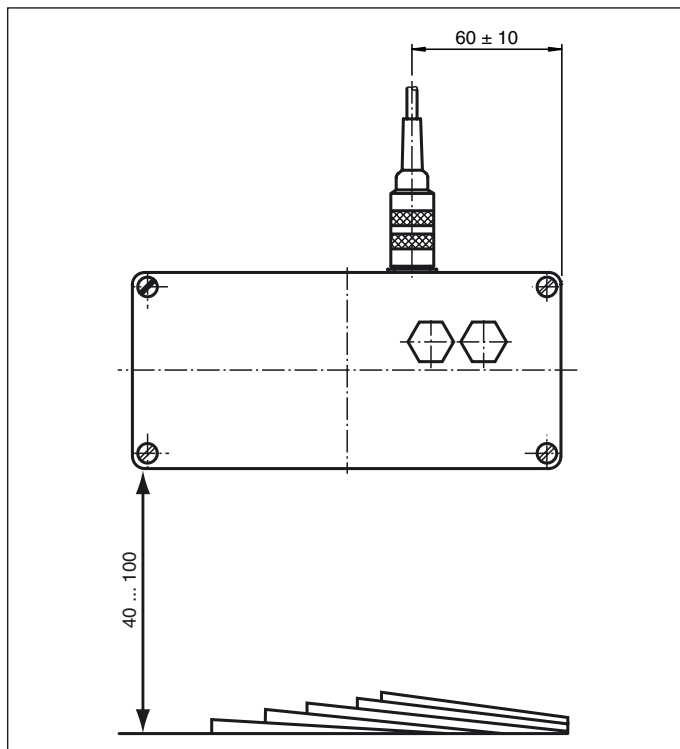

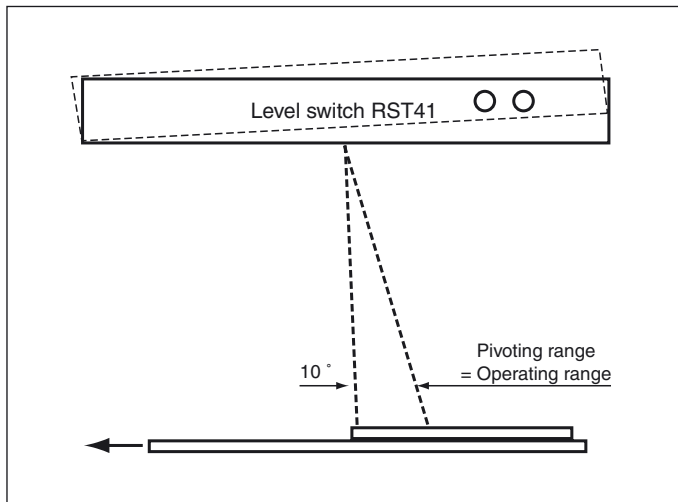

## Operating principle

### Application

Remission level sensors (RLS, German RST) with detection ranges of 40 mm or 100 mm are capable of detecting overlapping edges of flat objects that are being moved on conveyor equipment. They are suitable both for counting objects and for positioning objects.

Due to their high level resolution, RST40 or RST100 sensors are only suitable for unprinted objects.

### Applications

The RST40 can be used in the high-quality paper industry, for example the RST41 and RST100 in the packaging industry and the RST101 in the newspaper printing industry for counting and positioning. The off-delay, which is controlled by step pulses, makes it possible to record overlapped stacks as whole objects in systems equipped with an incremental pulse generator.

### Operating principle

Functionality is based on the fact that edges and slopes cast shadows. Each IR transmitter group alternately beams from the right or the left at the underlay on which the objects are being moved.

The light output of the right transmitter group is set at a higher level than that of the left transmitter group. The illuminated surface is observed by a photoelectric receiver that records a greater intensity of light on an even surface of any with the right transmitter turned on than with the left transmitter turned on. This signal reverses if an edge or shadow is detected.

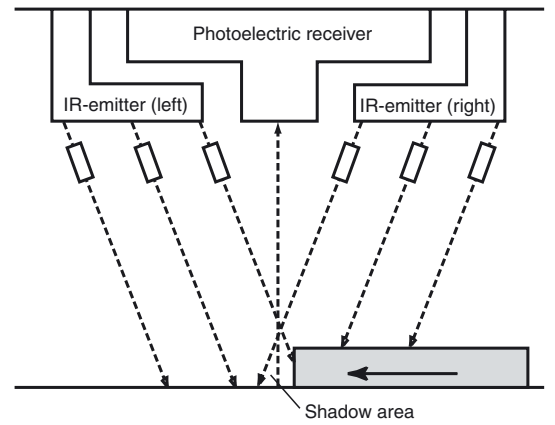

### Mounting/adjustment:

It follows from the working principle that the sensors must be oriented in a defined manner to the overlapping. There is an icon on the front side of the sensor indicating the position of the levels in the overlapping. The levels cannot be detected with assembly facing in opposite directions! The working principle is based on the fact that the sensors respond sensitively to an inclination in the direction of overlapping relative to the level of the object.

#### RST40, RST100

The sensors are only capable of working in an inclination range of about  $4^\circ$ . This angular range can fall within an inclination of  $\pm 10^\circ$  relative to the alignment parallel to the level of the object. Because of this, the sensors must be mounted so that they can rotate through  $\pm 10^\circ$ . A sensor mounted in this manner will be rotated in such a manner for an object lying underneath that is not inclined that the display switches from green to red. Then the sensor is rotated further by about  $2^\circ$ . For control, this is then extended to run one level under the sensor. Running through the level must change the display from red to green.

If this does not happen, the sensor has been moved too far in the direction of "Red display" and must be rotated back in the direction of "Basic display".

#### RST41, RST101

These do not require a rotating support and can be mounted without attention to critical details. They are also not sensitive to printing.

### Time functions

### Externally controlled time function

Devices come standard with a time function controlled externally via incremental pulses. The output is locked in the switched state by a shadow signal that is received. After an adjustable number of pulses is entered on control input 5, the output is locked and returns to the idle state (illustration).

Pulse counting for the off-delay starts with the disappearance of the shadow signal.

After the sealing plug on the device has been screwed out, two DIP switches are accessible. They can be used to adjust the pulse count until the output is reset to a number between 1 and 99.

The time function can be taken out of operation by means of control input 6 (0 V).

The device can also be optionally equipped with an IAB (pulse counting starts with the shadow signal) (option /9).

The external time function is suitable for counting overlapped stacks as a whole or for detecting smooth objects on a rough base (illustration). The time function in the form described here is also useful for bouncing suppressing when the edges of the shadows are moving around (for example in conveyor systems of newspaper printing systems).

### Internal time functions

For applications where no incremental pulses are available or where they should not be used, it is possible to equip the remission level sensor with an internal time function.

The internal time function lengthens the duration of the shadow signal (GAB) or generates a pulse (IAB) that starts when the shadow signal appears.

Time functions can be adjusted with the DIP switches. The numbers 0 ... 99, multiplied by the base delay of 1 ms (default) or 10 ms yield the approximate length of the time function. This results in an adjustment range of 1 ... 99 ms or 10 ... 990 ms.

Control input 5 is used to select the time function GAB or IAB.

### Please note:

When ordering, it is essential to indicate the desired time period together with the term '-internal-'.  
For example RST41, internal 1 ... 99 ms

### Description of control inputs

The device has two control inputs that are activated by potential-free contacts or by NPN transistors against 0 V. Control input 5 has the following functions:

- with external time function, input of incremental pulses
- with internal time function, switching between GAB and IAB.

Control input 6 has the following function:

- Turn off the time function or direct reset of the output after a shadow signal has been received.

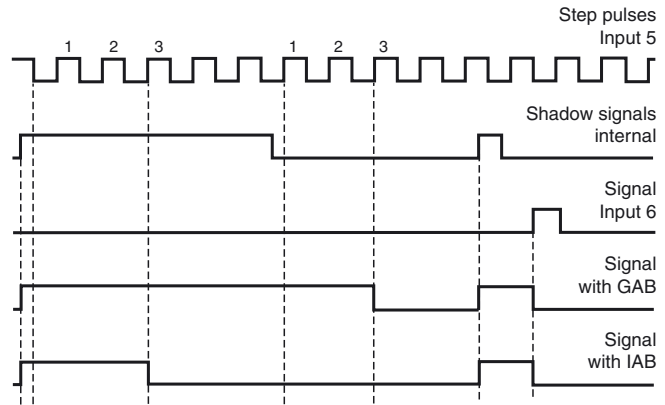

Control of GAB or IAB with incremental pulses on input 5 and by an active signal on Input 6. The setting made for the incremental pulse number is  $n = 3$ .

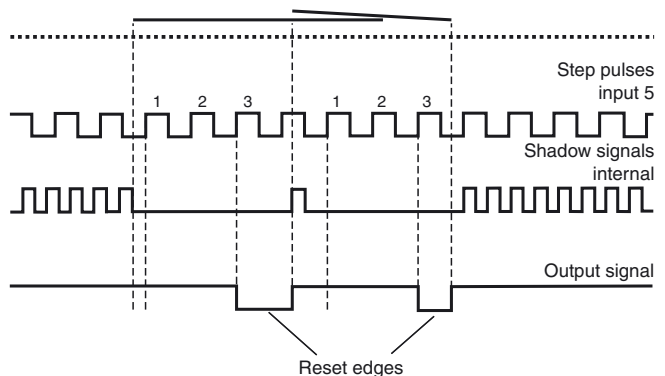

Counting smooth objects on a rough subsurface: GAB or IAB controlled by external incremental pulses (in the example, the setting is  $n = 3$ ). Reset edges are counted.