

**Model Number**

**OMH-SLCT-01**

Quick clamp and adjustment system

**Features**

- Mounting bracket
- Simple and fast mounting

**Dimensions**

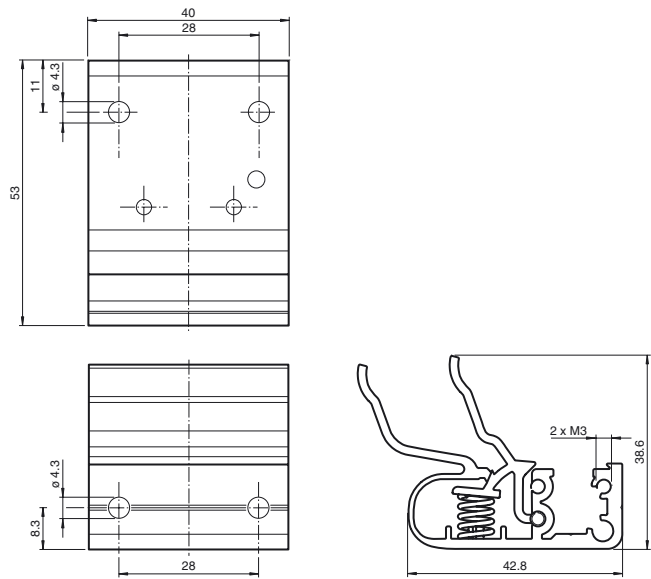

**Technical data**

**General specifications**

Setting angle  $\pm 7^\circ$

**Mechanical specifications**

Material aluminium  
 Mass approx. 36 g

**Suitable series**

Safety Series SLCT  
 SLCS

**Mounting note**

Rear view and lateral mounting.

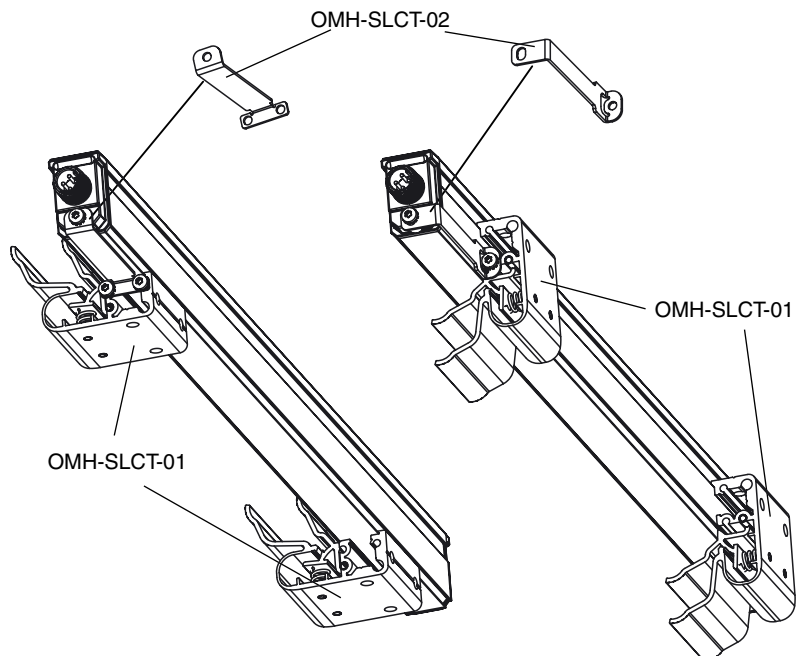

Release date: 2009-11-26 11:06 Date of issue: 2009-11-26 208706\_ENG.xml