



Model Number

VDM35-6-L/20/115b/122

Distance sensor
with 0.2 m fixed cable and M12 connector, 5-pin

Features

- Can be aligned using an integrated pilot laser
- Adjustable switch outputs
- Not sensitive to ambient light
- Analog output 4 mA ... 20 mA

Accessories

OMH-VDM35
Mounting aid

OMH-VDM35-01
Mounting aid

VDM35-AR
Alignment aid

Dimensions

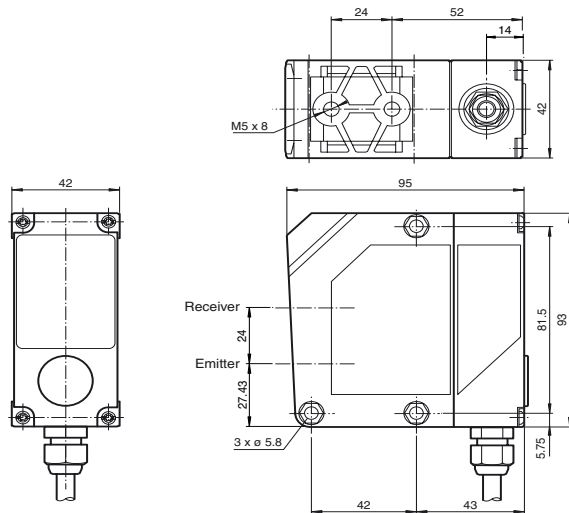

Electrical connection

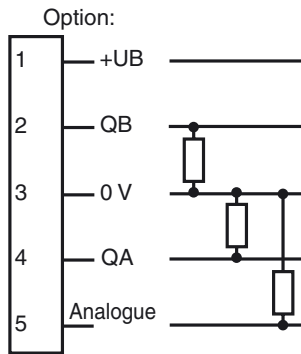

Pinout

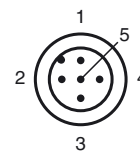

Indicators/operating means

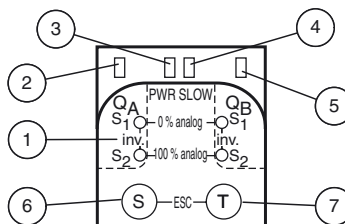

1	LED Menu	red
2	LED QA	yellow
3	LED Fast	orange
4	LED Power	green
5	LED QB	yellow
6	Button Set	
7	Button Toggle	

Release date: 2010-03-17 14:05 Date of issue: 2010-03-17 207894_ENG.xml

Additional accessories can be found in the Internet.

Subject to modifications without notice

Pepperl+Fuchs Group
www.pepperl-fuchs.com

USA: +1 330 486 0001
fa-info@us.pepperl-fuchs.com

Germany: +49 621 776-4411
fa-info@pepperl-fuchs.com

Copyright Pepperl+Fuchs
Singapore: +65 6779 9091
fa-info@sg.pepperl-fuchs.com

Technical data**General specifications**

Reference target	Kodak white (90%)
Light source	laser diode
Light type	modulated visible red light modulated infrared light
Laser nominal ratings	
Note	VISIBLE AND INVISIBLE LASER RADIATION , DO NOT STARE INTO BEAM
Laser class	Measurement laser: 1 Alignment laser: 2
wave length	Measurement laser: 905 nm Alignment laser: 650 nm
Beam divergence	Measurement laser: 2 mrad Alignment laser: 1 mrad
Pulse length	Measurement laser: 6 ns Alignment laser: 0.25 μ s
Repetition rate	Measurement laser: 40 kHz Alignment laser: 1 kHz
Maximum optical power output	Measurement laser: 1.8 W Alignment laser: 3 mW
Approvals	CE
Measuring method	Time of flight measurement
Measurement range	0.2 ... 6 m
Diameter of the light spot	4 mm x 12 mm at a distance of 6 m
Ambient light limit	5000 Lux
Temperature influence	typ. \leq 1.2 mm/K

Indicators/operating means

Operating display	LED green
Function display	LED yellow: switching state (2x) , LED orange : Operating mode
Controls	Control panel : Adjuster for switch point , Operating mode , Analog output (S - Set , T - Toggle)
Parameterization display	LED red (4x)

Electrical specifications

Operating voltage	U_B	18 ... 30 V DC , class 2
Ripple		10 % within the supply tolerance
No-load supply current	I_0	\leq 125 mA / 24 V DC
Time delay before availability	t_v	\leq 300 ms

Output

Switching type	light/dark on, switchable	
Signal output	2 pnp, short-circuit proof	
Switching current	max. 100 mA	
Measurement output	1 analog output 4 ... 20 mA, short-circuit/overload protected , $R_{max} = 500$ Ohm	
Voltage drop	U_d	\leq 2.4 V
Deviation of the characteristic curve		typ. $\leq \pm$ 40 mm
Switching frequency	f	Fast: 40 Hz / Slow: 16 Hz
Response time		Fast: 13 ms / Slow: 80 ms
Repeat accuracy	R	Fast: $\leq \pm$ 15 mm / Slow: $\leq \pm$ 10 mm

Ambient conditions

Ambient temperature	-20 ... 50 °C (-4 ... 122 °F)
Storage temperature	-40 ... 80 °C (-40 ... 176 °F)

Mechanical specifications

Protection degree	IP67
Connection	fixed cable 200 mm with M12 connector, 5 pin
Material	
Housing	ABS
Optical face	PMMA
Mass	200 g

Compliance with standards and directives

Directive conformity	
EMC Directive 2004/108/EC	EN 60947-5-2
Standard conformity	
Laser class	IEC 60825-1:2001

Curves/Diagrams

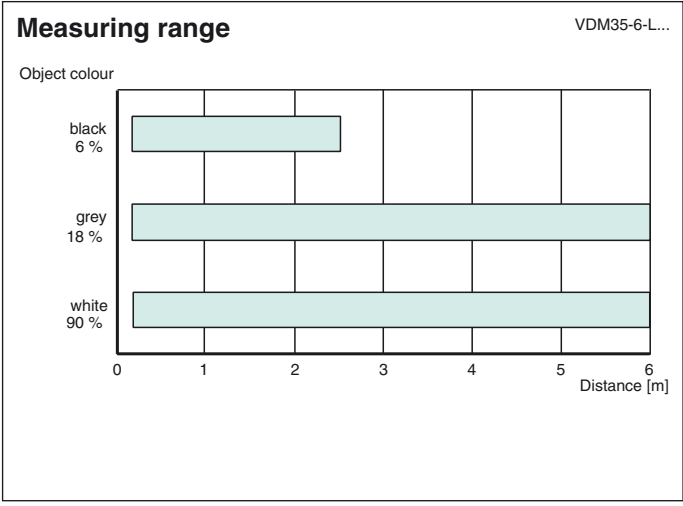
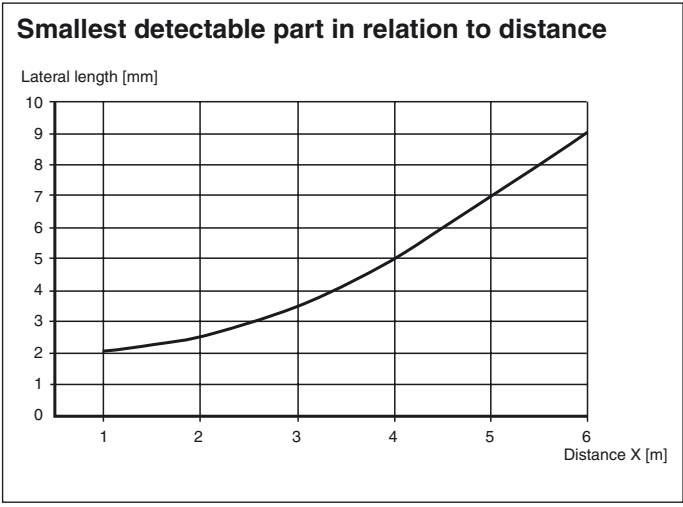
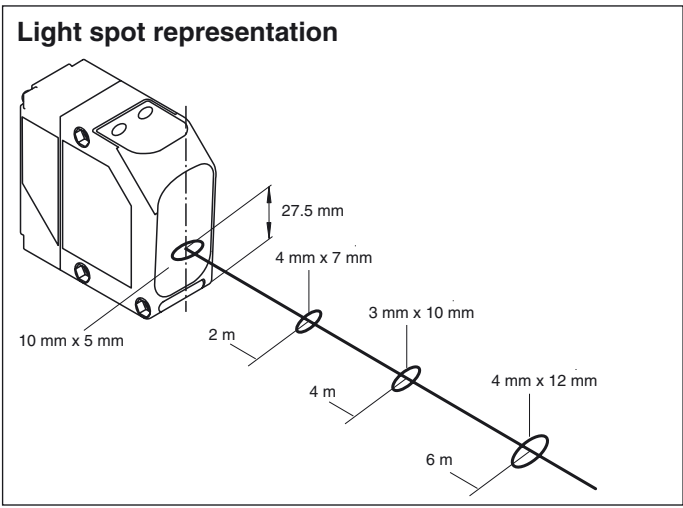

Release date: 2010-03-17 14:05 Date of issue: 2010-03-17 207894_ENG.xml

