



CE

Model Number

OMH-SLCT-04

Mounting bracket including adjustment
(with loose bearing)

Features

- Mounting bracket
- Simple and fast mounting

Dimensions

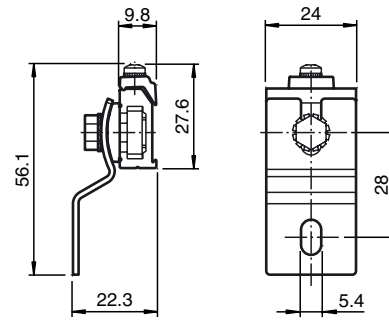

Technical data

General specifications

Setting angle $\pm 7^\circ$

Mechanical specifications

Material aluminium
Mass approx. 34 g

Suitable series

Safety Series SLCT
SLCS

Mounting note

