



Model Number

TR 14/30/50/60

Test rod for safety light curtain SLCT

Features

- Universal test rod for device test of all light curtains from the SLCT and SLCS series

Test rod for testing resolution

Dimensions

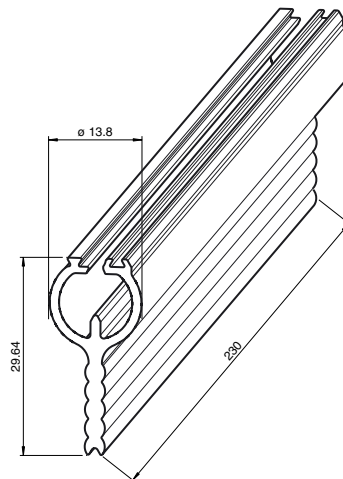

Technical data

Mechanical specifications

Material	aluminium
Mass	approx. 105 g

Suitable series

Safety Series	SLCT SLCS
---------------	--------------

Indicators / operating means

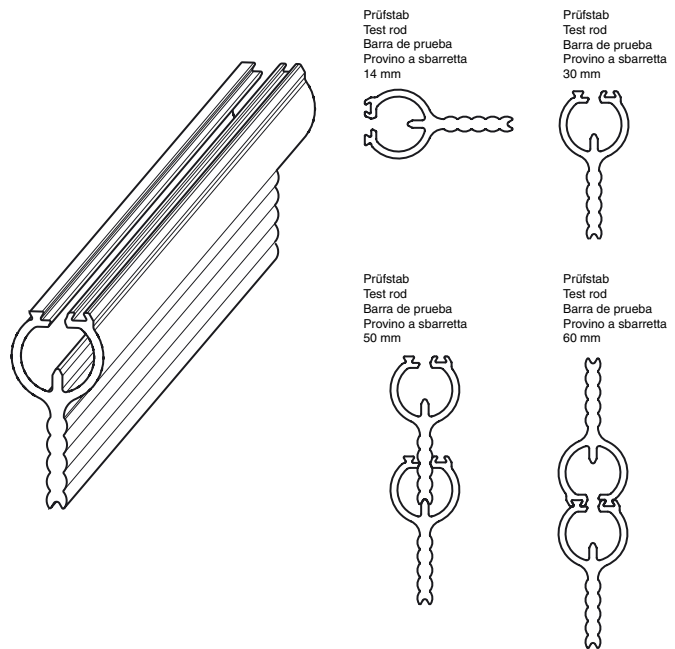

Release date: 2008-03-25 16:32 Date of issue: 2008-03-25 205992_ENG.xml