



Model Number

VDM100-150-P

Distance measurement device with four M12 x 1 connectors

Features

- Measuring method PRT (Pulse Ranging Technology)
- Non-contact precision measurement
- Ultra-fast data acquisition
- Active dynamic control
- Modern lightweight design, extremely robust
- Simple programming with 4 keys and luminous display

Product information

Series VDM 100 laser distance measurement devices are designed for high distances. They have a repeat accuracy of 0.5 mm. SSI and fieldbusses are used as value interfaces.

These devices are used for precise positioning of rack operating units, gantry cranes, rail-bound vehicles, elevators and other linear movable units.

Dimensions

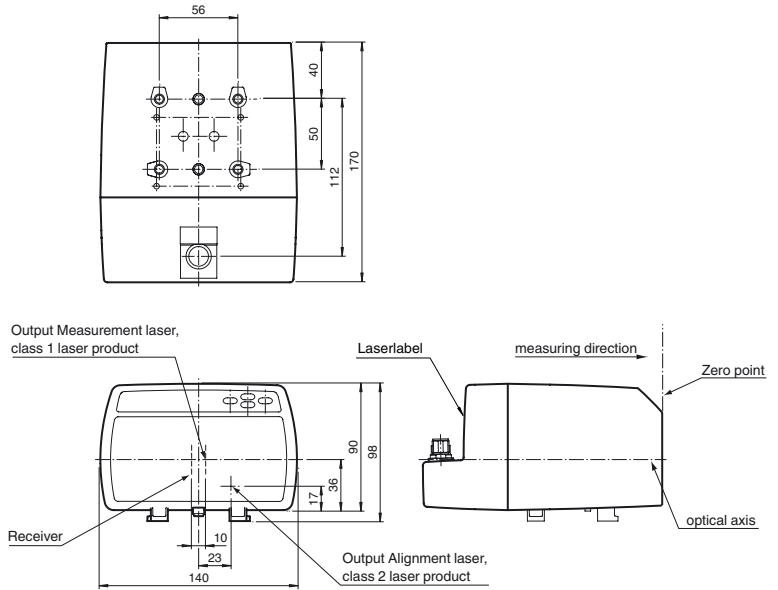

Electrical connection

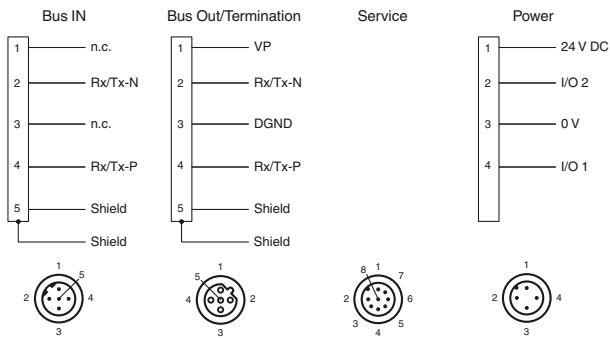

Indicators/operating means

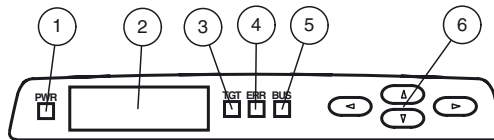

1	Power-LED	green
2	Display	
3	TARGET-LED	green
4	ERROR-LED	red
5	BUS-LED	green
6	Control keys	

Release date: 2013-01-25 10:20 Date of issue: 2013-02-18 204896_eng.xml

Subject to modifications without notice

Pepperl+Fuchs Group
www.pepperl-fuchs.com

USA: +1 330 486 0001
fa-info@us.pepperl-fuchs.com

Germany: +49 621 776-4411
fa-info@pepperl-fuchs.com

Copyright Pepperl+Fuchs
Singapore: +65 6779 9091
fa-info@sg.pepperl-fuchs.com

Technical data**General specifications**

Measurement range	0.3 ... 150 m
Reference target	Foil reflector 500 mm x 500 mm
Light source	laser diode
Laser nominal ratings	
Note	VISIBLE AND INVISIBLE LASER RADIATION , DO NOT STARE INTO BEAM
Laser class	Measurement laser: 1 Alignment laser: 2
Wave length	Measurement laser: 905 nm Alignment laser: 660 nm
Beam divergence	Measurement laser: 2 mrad Alignment laser: 1 mrad
Pulse length	Measurement laser: 4 ns
Repetition rate	Measurement laser: 20 kHz
Maximum optical power output	
max. pulse energy	Alignment laser: 0.6 mW Measurement laser: 12 nJ
Measuring method	Pulse Ranging Technology (PRT)
Max. Motion velocity	15 m/s
Alignment aid	Laserpointer
Life span	> 100000 h
Diameter of the light spot	35 cm at 150 m
Ambient light limit	> 100000 Lux
Resolution	0.1 mm , adjustable
Temperature influence	0.03 mm/K
Functional safety related parameters	
MTTF _d	89 a
Mission Time (T _M)	20 a
Diagnostic Coverage (DC)	0 %
Indicators/operating means	
Function display	4 LEDs
Controls	Control panel (4 membrane keys) for setting parameters
Parameterization display	Illuminated display for displaying measured values and parameterization
Electrical specifications	
Operating voltage	U _B 18 ... 30 V DC
No-load supply current	I ₀ 250 mA (18 V) ... 150 mA (30 V)
Protection class	III (operating voltage 50 V)
Time delay before availability	t _v < 10 s
Interface	
Interface type	PROFIBUS DP acc. to EN 50170
Transfer rate	9.6 kbit/s ... 12 Mbit/s , adjustable
Input/Output	
Input/output type	2 PNP inputs/outputs, independent configuration, short-circuit protected, reverse polarity protected
Input	
Switching threshold	low: U _e < 6 V, high: U _e > 16 V
Output	
Switching threshold	low: U _a < 1 V, high: U _a > U _b - 1 V
Switching current	200 mA per output
Measurement accuracy	
Measured value output	1 ms
Average data age	3 ms , 6 ms , 12 ms , 25 ms , 50 ms , adjustable
Offset	max. 2 mm (between two devices)
Absolute accuracy	± 2.5 mm (> 3 m); ± 3.5 mm (0.3 m to 3 m)
Repeat accuracy	< 0.5 mm
Ambient conditions	
Ambient temperature	-10 ... 50 °C (14 ... 122 °F)
Storage temperature	-20 ... 70 °C (-4 ... 158 °F)
Relative humidity	95 % , no moisture condensation
Mechanical specifications	
Protection degree	IP65
Connection	4-pin, M12x1 connector, standard (supply) , 5-pin, M12x1 connector, B-coded (Bus In) , M12x1 socket, 5-pin, B-coded (Bus Out) , 8-pin M12x1 connector, service
Material	
Housing	ABS / PC
Optical face	PMMA , hard coated
Mass	approx. 700 g
Compliance with standards and directives	

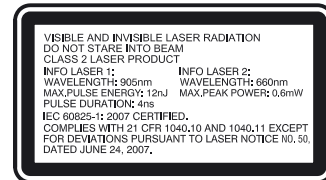
Laserlabel**Accessories****V15-G-PG9**

Cable socket, M12, 5-pin, ready for assembly

V15-W-PG9

Cable socket, M12, 5-pin, ready for assembly

V1-W

4-pin, M12 female field-attachable connector

V1-G

4-pin, M12 female field-attachable connector

V15B-G-ABG-PG9

Cable socket, M12, for PROFIBUS, adjustable

V15SB-G-ABG-PG9

Cable connector, M12, for PROFIBUS, adjustable

ICZ-TR-V15B

Terminal resistor for PROFIBUS

Schutzkappe LS610 Zubehoer

M12 protective cap set (connector + socket) for series LS610 / LS611

Funktionserdung LS610/VDM100 Zubehoer

Function grounding for LS610 / LS611 / VDM100 series

OMH-VDM100-01

Mounting bracket with deviation mirror for distance measurement devices

OMH-LS610-01

Mounting bracket for optical data coupler

OMH-LS610-02

Direct mounting set consisting of 4 x M4 threaded inserts

OMH-LS610-03

Mounting bracket with deviation mirror for optical data coupler

OMH-LS610-04

Hood

OMH-LS610-05

Mounting bracket for optical data coupler and distance measurement devices

OMH-LS610-31

Mounting bracket for optical data coupler and distance measurement devices

OMH-LS610-32

Mounting bracket for optical data coupler and distance measurement devices

Directive conformity	EMC Directive 2004/108/EC
Standard conformity	
Product standard	EN 60947-5-2:2007
Laser class	IEC 60825-1:2007

Approvals and certificates

UL approval	cULus Listed
-------------	--------------

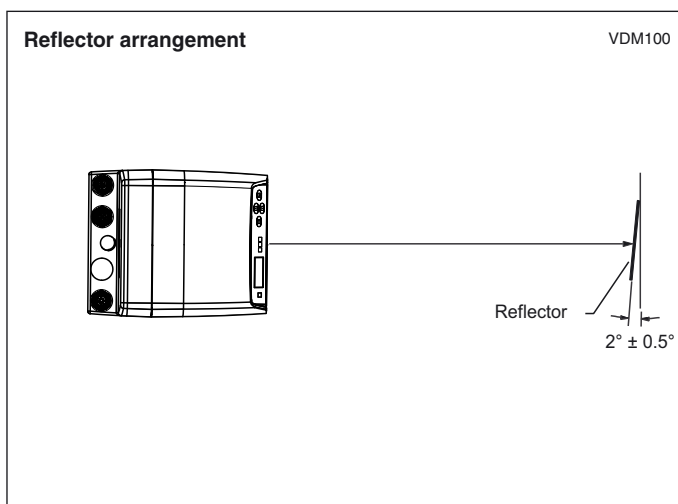
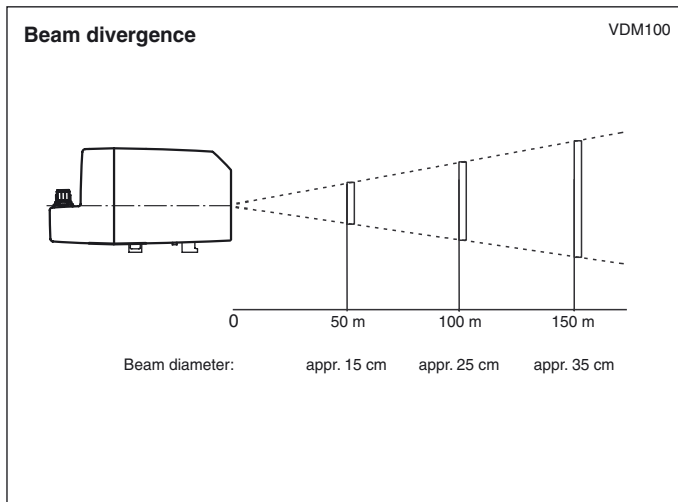
Curves/Diagrams**Laser notice laser class 2**

- Caution: visible and invisible laser radiation, do not look at the beam!
- The irradiation can lead to irritation especially in a dark environment. Do not point at people!
- Maintenance and repairs should only be carried out by authorized service personnel!
- Attach the device so that the warning is clearly visible and readable.
- Caution – Use of controls or adjustments or performance of procedures other than those specified herein may result in hazardous radiation exposure.