



Model Number

NBB20-U1-A0-T

Features

- 20 mm embeddable
- 4-wire DC
- 4 LEDs indicator for 360° visibility
- Temperature range -25 ... 100 °C (-13 ... 212 °F)
- 20 mm not embeddable

Connection

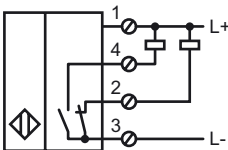

Accessories

V1-M20-80

Receptacles, M12/M20; plastic version

MHW 01

Modular mounting bracket

MH 04-2681F

Mounting aid for VariKont, +U1+ and +U9*

Dimensions

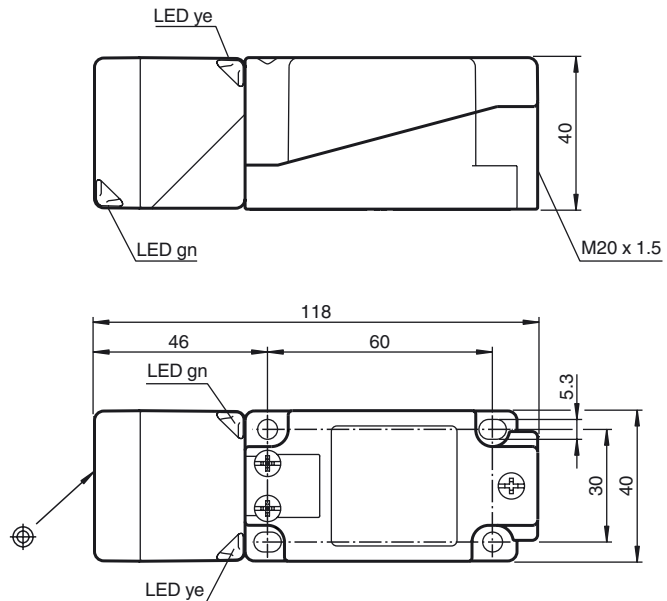

Technical Data

General specifications

Switching element function		NPN	NO/NC
Rated operating distance	s_n	20 mm	
Installation		embeddable	
Output polarity		DC	
Assured operating distance	s_a	0 ... 16.2 mm	
Reduction factor r_{AI}		0.35	
Reduction factor r_{CU}		0.3	
Reduction factor r_{303}		0.75	

Nominal ratings

Operating voltage	U_B	10 ... 30 V DC
Switching frequency	f	0 ... 300 Hz
Hysteresis	H	typ. 5 %
Reverse polarity protected		reverse polarity protected
Short-circuit protection		pulsing
Voltage drop	U_d	≤ 2 V
Operating current	I_L	0 ... 200 mA
Off-state current	I_r	0 ... 0.5 mA
No-load supply current	I_0	≤ 20 mA
Operating voltage display		LED, green
Indication of the switching state		LED, yellow

Ambient conditions

Ambient temperature	-25 ... 100 °C (-13 ... 212 °F)
---------------------	---------------------------------

Mechanical specifications

Connection type	screw terminals
Core cross-section	≤ 2.5 mm ²
Housing material	PA / LCP
Sensing face	PA
Housing base	plastic
Protection degree	IP68 / IP69K
Mass	225 g
Note	Tightening torque: 1.8 Nm (housing) Tightening torque: 1.0 Nm (Screw terminal)

Compliance with standards and directives

Standard conformity	
Standards	EN 60947-5-2:2007 IEC 60947-5-2:2007

Approvals and certificates

UL approval	cULus Listed, General Purpose
CSA approval	cCSAus Listed, General Purpose
CCC approval	Products with a maximum operating voltage of ≤ 36 V do not bear a CCC marking because they do not require approval.