



Model Number

NBB15-U4-E2-V1

Features

- 4 LEDs indicator for 360° visibility
- 15 mm embeddable

Connection

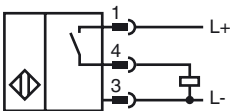

Pinout

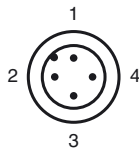

Wire colors in accordance with EN 60947-5-2

1	BN	(brown)
2	WH	(white)
3	BU	(blue)
4	BK	(black)

Accessories

MHW 01

Modular mounting bracket

V1-G

4-pin, M12 female field-attachable connector

V1-W

4-pin, M12 female field-attachable connector

Dimensions

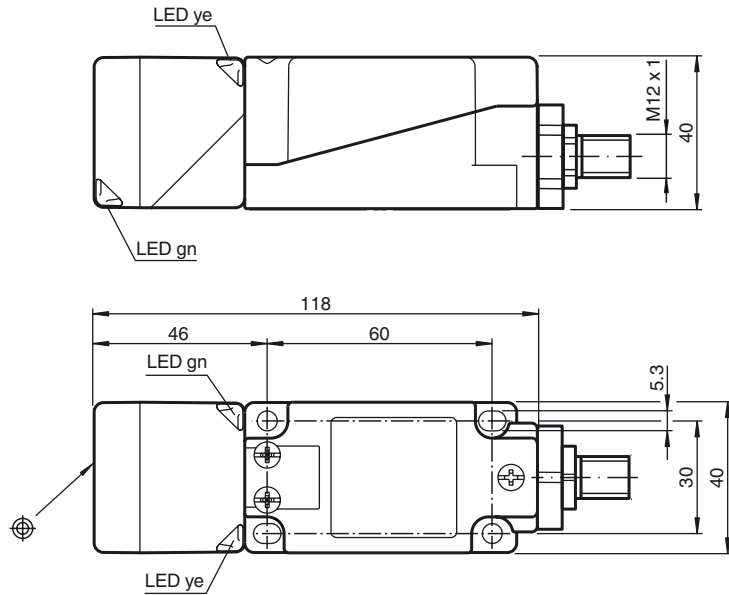

Technical Data

General specifications

Switching element function	PNP	NO
Rated operating distance	s_n	15 mm
Installation		embeddable
Output polarity		DC
Assured operating distance	s_a	0 ... 12.15 mm
Reduction factor r_{Al}		0.33
Reduction factor r_{Cu}		0.31
Reduction factor r_{303}		0.74
Reduction factor r_{Brass}		0.41

Nominal ratings

Operating voltage	U_B	10 ... 30 V
Switching frequency	f	0 ... 200 Hz
Hysteresis	H	typ. 5 %
Reverse polarity protected		reverse polarity protected
Short-circuit protection		pulsing
Voltage drop	U_d	≤ 2 V
Operating current	I_L	0 ... 200 mA
Off-state current	I_r	0 ... 0.5 mA typ. 0.01 mA
No-load supply current	I_0	≤ 20 mA
Operating voltage display		LED, green
Indication of the switching state		LED, yellow

Functional safety related parameters

MTTF _d	1460 a
Mission Time (T _M)	20 a
Diagnostic Coverage (DC)	0 %

Ambient conditions

Ambient temperature	-25 ... 85 °C (-13 ... 185 °F)
---------------------	--------------------------------

Mechanical specifications

Connection type	Device connector M12 x 1, 4-pin
Housing material	PA/metal with epoxy powder coating
Sensing face	PA
Housing base	metal
Protection degree	IP68 / IP69K
Mass	225 g
Note	Tightening torque: 1.8 Nm (housing)

Compliance with standards and directives

Standard conformity	
Standards	EN 60947-5-2:2007 IEC 60947-5-2:2007

Approvals and certificates

UL approval	cULus Listed, General Purpose
CSA approval	cCSAus Listed, General Purpose
CCC approval	Products with a maximum operating voltage of ≤ 36 V do not bear a CCC marking because they do not require approval.

Release date: 2011-08-15 13:29 Date of issue: 2011-08-15 203030_eng.xml