



Model Number

NBB15-U4-E0

Features

- 4 LEDs indicator for 360° visibility
- 15 mm embeddable

Connection

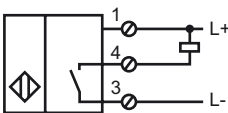

Accessories

MHW 01

Modular mounting bracket

V1-M20-80

Receptacles, M12/M20; plastic version

V1-G

4-pin, M12 female field-attachable connector

V1-W

4-pin, M12 female field-attachable connector

Dimensions

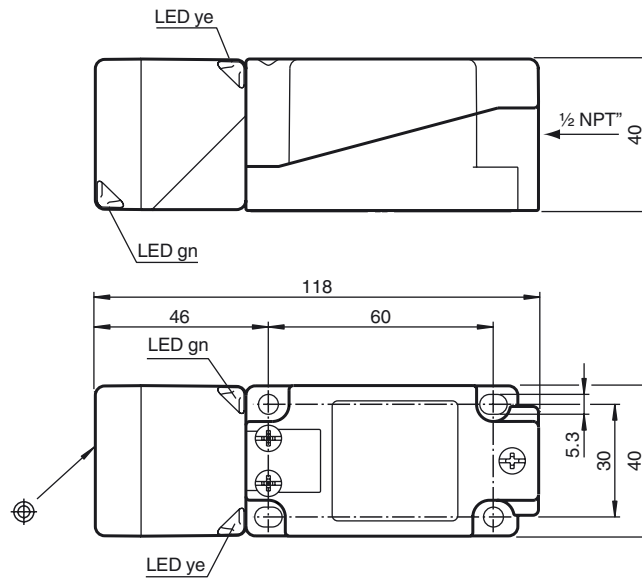

Technical Data

General specifications

Switching element function	NPN	NO
Rated operating distance	s_n	15 mm
Installation	embeddable	
Output polarity	DC	
Assured operating distance	s_a	0 ... 12.15 mm
Reduction factor r_{AI}	0.33	
Reduction factor r_{Cu}	0.31	
Reduction factor r_{303}	0.74	
Reduction factor r_{Brass}	0.41	

Nominal ratings

Operating voltage	U_B	10 ... 30 V
Switching frequency	f	0 ... 200 Hz
Hysteresis	H	typ. 5 %
Reverse polarity protected	reverse polarity protected	
Short-circuit protection	pulsing	
Voltage drop	U_d	≤ 2 V
Operating current	I_L	0 ... 200 mA
Off-state current	I_r	0 ... 0.5 mA typ. 0.1 μ A at 25 °C
No-load supply current	I_0	≤ 20 mA
Operating voltage display	LED, green	
Indication of the switching state	LED, yellow	

Functional safety related parameters

MTTF _d	1510 a
Mission Time (T _M)	20 a
Diagnostic Coverage (DC)	0 %

Ambient conditions

Ambient temperature	-25 ... 85 °C (-13 ... 185 °F)
---------------------	--------------------------------

Mechanical specifications

Connection type	screw terminals
Core cross-section	≤ 2.5 mm ²
Housing material	PA/metal with epoxy powder coating
Sensing face	PA
Housing base	metal
Protection degree	IP68 / IP69K
Mass	225 g
Note	Tightening torque: 1.8 Nm (housing) Tightening torque: 1.0 Nm (Screw terminal)

Compliance with standards and directives

Standard conformity	
Standards	EN 60947-5-2:2007 IEC 60947-5-2:2007

Approvals and certificates

UL approval	cULus Listed, General Purpose
CSA approval	cCSAus Listed, General Purpose
CCC approval	Products with a maximum operating voltage of ≤ 36 V do not bear a CCC marking because they do not require approval.

Release date: 2011-08-15 14:13 Date of issue: 2011-08-15 203025_eng.xml

Subject to modifications without notice

Pepperl+Fuchs Group
www.pepperl-fuchs.com

USA: +1 330 486 0001
fa-info@us.pepperl-fuchs.com

Germany: +49 621 776-4411
fa-info@pepperl-fuchs.com

Copyright Pepperl+Fuchs
Singapore: +65 6779 9091
fa-info@sg.pepperl-fuchs.com