



Model Number

NDN20-F97-EHB100

Features

- Block control for flow of internal company materials
- Replacement for power rail section
- Measurement range 500 mm

Connection

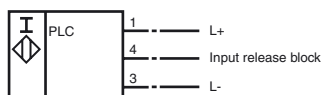

Dimensions

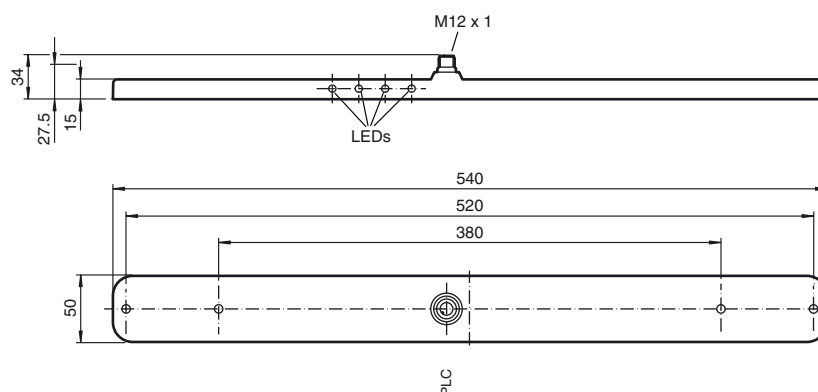

Technical Data

General specifications

Installation	non-flush
Output polarity	DC

Nominal ratings

Operating voltage	U_B	24 V DC
Reverse polarity protected		reverse polarity protected
Short-circuit protection		pulsing
Operating current	I_L	0 ... 100 mA
No-load supply current	I_0	≤ 25 mA
Operating voltage display		LED, green
Indication of the switching state		LED red: locked LED green: block on

Functional safety related parameters

MTTF _d	1050 a
Mission Time (T _M)	20 a
Diagnostic Coverage (DC)	0 %

Ambient conditions

Ambient temperature	0 ... 50 °C (32 ... 122 °F)
---------------------	-----------------------------

Mechanical specifications

Housing material	ABS
Sensing face	ABS
Protection degree	IP67

Compliance with standards and directives

Standard conformity	
Standards	EN 60947-5-2:2007 IEC 60947-5-2:2007

Approvals and certificates

CCC approval	Products with a maximum operating voltage of ≤36 V do not bear a CCC marking because they do not require approval.
--------------	--