



Model Number

VDM70-250-R/20/87/160

Distance measurement device
12-pin M16 connector

Features

- Distance measurement using reflector
- Measuring method PRT (Pulse Ranging Technology)
- Can be aligned using an integrated pilot laser
- SSI interface
- Adjustable switch outputs
- Not sensitive to ambient light

Dimensions

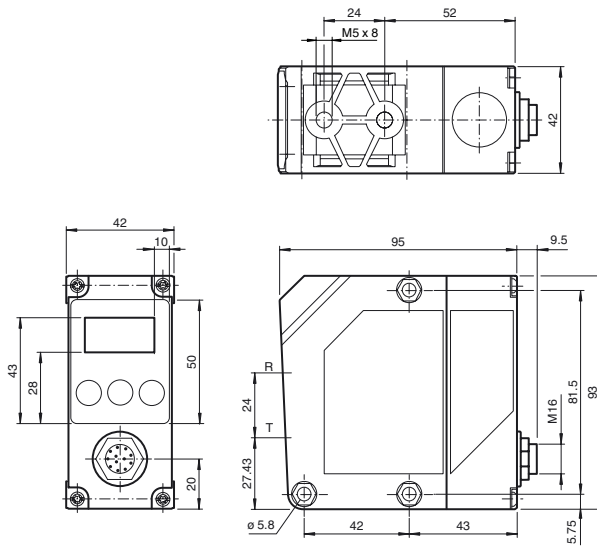

Electrical connection

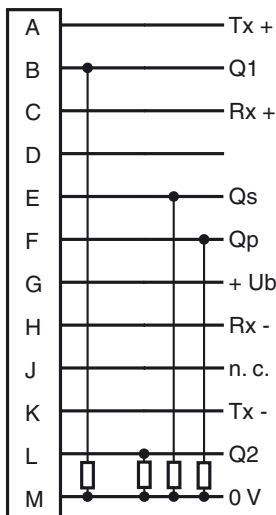

Release date: 2013-01-23 16:18 Date of issue: 2013-02-18 197453_eng.xml

Subject to modifications without notice

Pepperl+Fuchs Group
www.pepperl-fuchs.com

USA: +1 330 486 0001
fa-info@us.pepperl-fuchs.com

Germany: +49 621 776-4411
fa-info@pepperl-fuchs.com

Copyright Pepperl+Fuchs

Singapore: +65 6779 9091
fa-info@sg.pepperl-fuchs.com

Technical data**General specifications**

Measurement range	0.5 ... 250 m on reflector
Reference target	REF-VDM05
Light source	laser diode
Light type	modulated visible red light modulated infrared light
Laser nominal ratings	
Note	VISIBLE AND INVISIBLE LASER RADIATION , DO NOT STARE INTO BEAM
Laser class	Measurement laser: 1 Alignment laser: 2
Wave length	Measurement laser: 905 nm Alignment laser: 650 nm
Beam divergence	Measurement laser: 2 mrad Alignment laser: 1 mrad
Pulse length	Measurement laser: 6 ns Alignment laser: 0.25 µs
Repetition rate	Measurement laser: 40 kHz Alignment laser: 1 kHz
Maximum optical power output	Measurement laser: 1.8 W Alignment laser: 3 mW
Measuring method	Pulse Ranging Technology (PRT)
Linearity error	+/- 3 mm
Absolute accuracy	± 8 mm
Diameter of the light spot	20 mm x 20 mm at a distance of 10 m
Resolution	0.1 mm or 0.125 mm
Hysteresis	H min. 10 mm (adjustable)
Temperature influence	< ± 5 mm absolute

Functional safety related parameters

MTTF _d	230 a
Mission Time (T _M)	20 a
Diagnostic Coverage (DC)	0 %

Indicators/operating means

Operating display	LED green
Function display	LED yellow: switching state , LED orange : error message
Controls	Keypad (3 membrane keys) for parameter settings on the LCD display

Electrical specifications

Operating voltage	U _B	18 ... 30 V DC
Ripple		10 % within the supply tolerance
No-load supply current	I ₀	190 mA

Interface

Interface type	RS 422, SSI
----------------	-------------

Output

Interfaces	RS 422, SSI
Signal output	2 PNP, short-circuit protected, reverse polarity protected
Switching current	100 mA
Response time	12 ms
Repeat accuracy	R ± 2 mm
Other outputs	Service output, plausibility output, PNP, short-circuit protected 50 mA

Ambient conditions

Ambient temperature	-10 ... 50 °C (14 ... 122 °F)
Storage temperature	-30 ... 75 °C (-22 ... 167 °F)

Mechanical specifications

Protection degree	IP67
Connection	12-pin M16 connector
Material	
Housing	ABS
Optical face	PMMA
Mass	230 g

Compliance with standards and directives

Directive conformity	
EMC Directive 2004/108/EC	EN 60947-5-2
Standard conformity	
Laser class	IEC 60825-1:2007 EN 60825-1:2007

Approvals and certificates

Protection class	II
UL approval	cULus

Accessories**OMH-VDM35-01**

Adjustment set series VDM35

VDM35-AR

Alignment aid for VDM35 and VDM70 series

OMH-VDM35

Mounting bracket

REF-VDM05

Reflector for distance measurement devices

42312BOther suitable accessories can be found at www.pepperl-fuchs.com

Curves/Diagrams

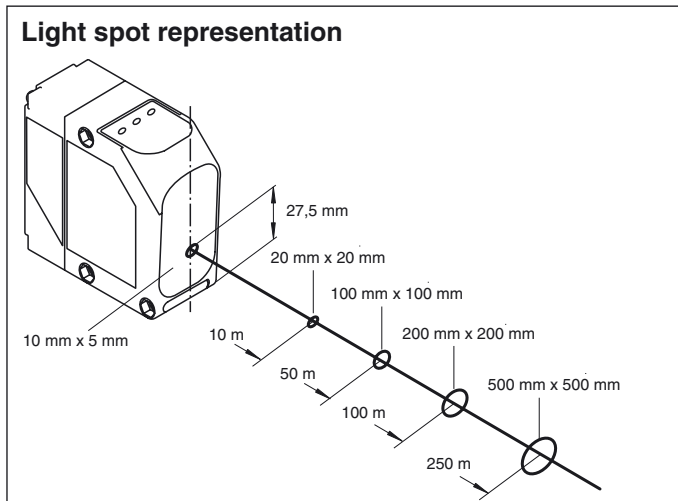

Reflectors	recommended detection range
REF-250MMx250MM	80 m
REF-500MMx500MM	100 m
REF-1000MMx1000MM	120 m
REF-VDM01	200 m
REF-VDM05	250 m