

Universal Power Rail with DIN rail and cover, 5 leads

Features

- Gold plated 5-conductor insert in 35 mm DIN rail acc. to EN 60715
- Provides DC supply voltage and the bus connection to all equipped K-System modules
- Standard length 0.8 m (2.6 ft), simple to customize to application space
- Eliminates daisy-chains

Dimensions

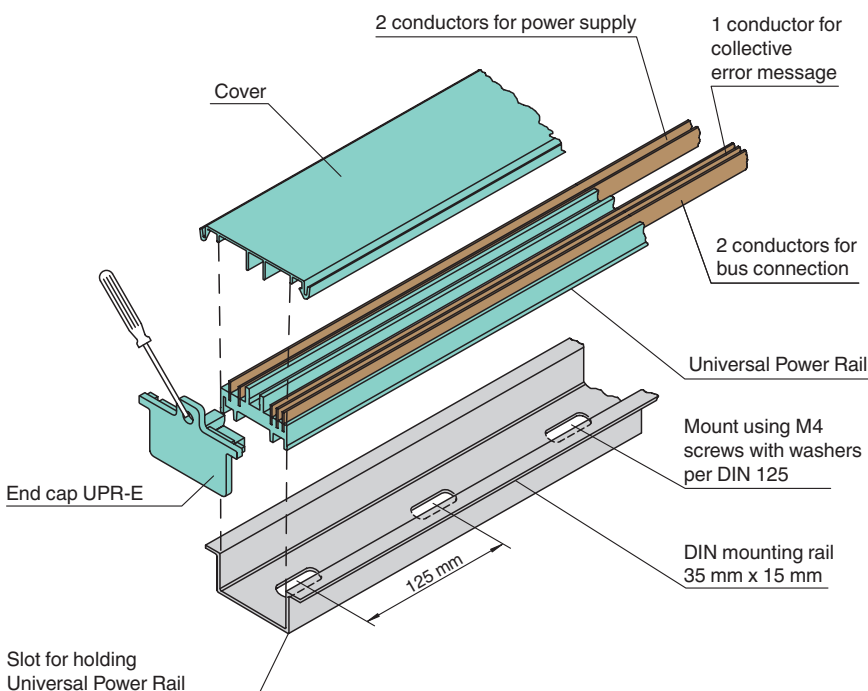

Technical data

Electrical specifications	
Rated voltage	24 V DC
Rated current	4 A
Ambient conditions	
Ambient temperature	-20 ... 60 °C (-4 ... 140 °F)
Mechanical specifications	
Dimensions	35 x 15 x 800 mm (1.4 x 0.6 x 31.5 in)
Mounting	mounting in 35 mm DIN mounting rail acc. to DIN EN 60715
Accessories	
Designation	optional accessories: - end cap UPR-E - insulation spacer UPR-I

Function

The universal Power Rail is a plastic insert with integral gold-plated conductors that fits into its own integral, 35 mm DIN rail and supplies components with power. It has two conductors for power, one conductor for collective error messaging, and two conductors for bus connections.

It reduces wiring and maintenance costs because it eliminates the need to daisy-chain the wires. It also simplifies expansion – just snap in a new module when you're ready to expand a system.

It comes in 0.8 m segments but can be cut to any size.

It is delivered with two UPR-E end caps. More end caps can be ordered separately. In conjunction with K-System modules the universal Power Rail can be mounted in Zone 2.



Cover empty, open segments of the Power Rail. Use the supplied cover. Thereby Power Rail will be protected from pollution. The contact with electrically conductive parts on Power Rail will be prevented.