



**Model Number**

NBB20-U1-E1

**Features**

- 4 LEDs indicator for 360° visibility
- 20 mm embeddable

**Connection**

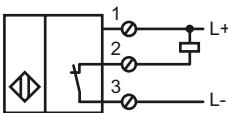

**Accessories**

**MHW 01**

Modular mounting bracket

**V1-M20-80**

Receptacles, M12/M20; plastic version

**V1-G**

4-pin, M12 female field-attachable connector

**V1-W**

4-pin, M12 female field-attachable connector

**Dimensions**

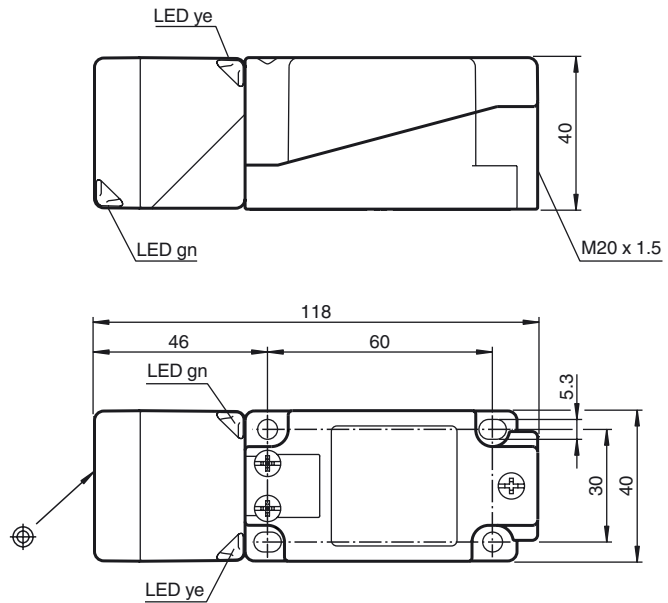

**Technical Data**

**General specifications**

Switching element function		NPN	NC
Rated operating distance	$s_n$	20 mm	
Installation		embeddable	
Output polarity		DC	
Assured operating distance	$s_a$	0 ... 16.2 mm	
Reduction factor $r_{AI}$		0.33	
Reduction factor $r_{Cu}$		0.31	
Reduction factor $r_{303}$		0.74	
Reduction factor $r_{Brass}$		0.41	

**Nominal ratings**

Operating voltage	$U_B$	10 ... 30 V
Switching frequency	$f$	0 ... 150 Hz
Hysteresis	$H$	typ. 5 %
Reverse polarity protected		reverse polarity protected
Short-circuit protection		pulsing
Voltage drop	$U_d$	$\leq 2$ V
Operating current	$I_L$	0 ... 200 mA
Off-state current	$I_r$	0 ... 0.5 mA typ. 0.1 $\mu$ A at 25 °C
No-load supply current	$I_0$	$\leq 20$ mA
Operating voltage display		LED, green
Indication of the switching state		LED, yellow

**Functional safety related parameters**

MTTF <sub>d</sub>	1460 a
Mission Time (T <sub>M</sub> )	20 a
Diagnostic Coverage (DC)	0 %

**Ambient conditions**

Ambient temperature	-25 ... 85 °C (-13 ... 185 °F)
---------------------	--------------------------------

**Mechanical specifications**

Connection type	screw terminals
Core cross-section	$\leq 2.5$ mm <sup>2</sup>
Housing material	PA/metal with epoxy powder coating
Sensing face	PA
Housing base	plastic
Protection degree	IP68 / IP69K
Mass	225 g
Note	Tightening torque: 1.8 Nm (housing) Tightening torque: 1.0 Nm (Screw terminal)

**Compliance with standards and directives**

Standard conformity	
Standards	EN 60947-5-2:2007 IEC 60947-5-2:2007

**Approvals and certificates**

UL approval	cULus Listed, General Purpose
CSA approval	cCSAus Listed, General Purpose
CCC approval	Products with a maximum operating voltage of $\leq 36$ V do not bear a CCC marking because they do not require approval.

Release date: 2011-08-15 14:16 Date of issue: 2011-08-15 194770\_eng.xml