



Model Number

RMS-D-RC

Radar sensor

Features

- Microwave motion sensor with intelligent functions
- Reliable detection of people and vehicles
- Direction detection
- Cross traffic suppression
- "Slow motion" for extremely slow motions
- Simplest adjustment of the sensing range
- Programmable by remote control

Product information

An effective opening of doors or industrial doors can be achieved very flexibly with the RMS microwave motion sensor series. The RC versions offer remote-controlled adjustment of parameters. Ultramodern microcontroller evaluation technology guarantees a variety of field sizes and universal use even in difficult conditions. The 24 GHz microwave technology enables a diverse range of operating modes such as direction detection. The cross-traffic suppression function only opens the door if people approach the door from the front, but not if they are walking past it. Thanks to the slow-motion mode, even extremely slow movements are detected, which increases convenience in senior citizens' residences, for example.

Dimensions

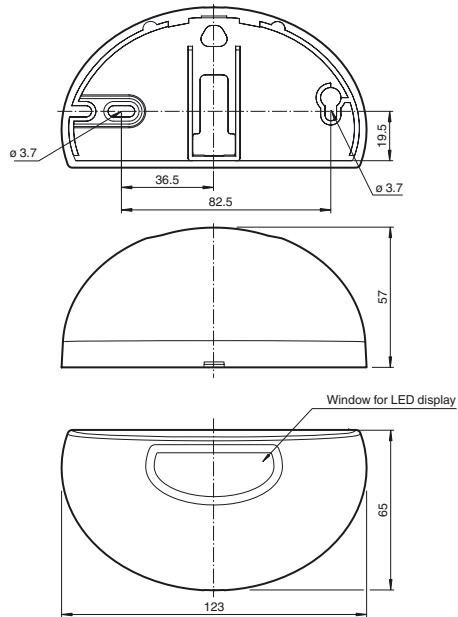

Electrical connection

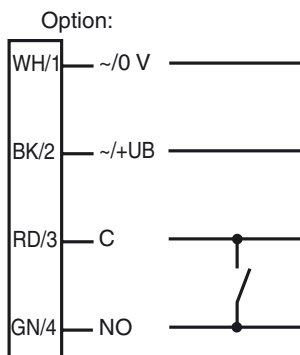

Indicators/operating means

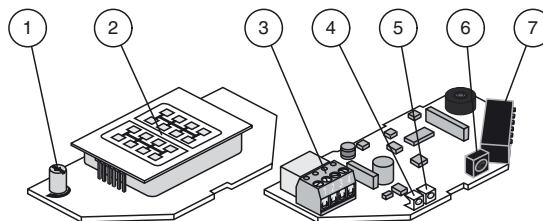

| | |
|---|----------------------------------|
| 1 | Potentiometer |
| 2 | Antenna |
| 3 | Terminal |
| 4 | IR transmitter (RC version only) |
| 5 | LED (red/green) |
| 6 | IR receiver (RC version only) |
| 7 | DIP switches |

Release date: 2012-05-30 17:06 Date of issue: 2012-08-16 18:4850_eng.xml

Subject to modifications without notice

Pepperl+Fuchs Group
www.pepperl-fuchs.com

USA: +1 330 486 0001
fa-info@us.pepperl-fuchs.com

Germany: +49 621 776-4411
fa-info@pepperl-fuchs.com

Copyright Pepperl+Fuchs
Singapore: +65 6779 9091
fa-info@sg.pepperl-fuchs.com

Technical data

General specifications

| | |
|-----------------------------------|---|
| Sensing range | 3000x 2500 mm (DxW) at 2200 mm mounting height and 30° tilt angle |
| Function principle | Microwave module |
| Detection speed | min. 0.1 m/s |
| Marking | CE |
| Setting angle | 0 ... 40 ° in 5 ° increments |
| Operating frequency | 24.15 ... 24.25 GHz K-Band |
| Operating mode | Radar motion sensor |
| Transmitter radiated power (EIRP) | < 20 dBm |

Functional safety related parameters

| | |
|--------------------------------|-------|
| MTTF _d | 640 a |
| Mission Time (T _M) | 20 a |
| Diagnostic Coverage (DC) | 0 % |

Indicators/operating means

| | |
|------------------|--|
| Function display | LED red/green |
| Controls | DIP-switch for selection of operating modes : Direction detection , Cross traffic suppression , Slow-motion , Switching type |
| Controls | sensitivity adjustment |
| Controls | Adjustment for off delay |

Electrical specifications

| | | |
|------------------------|----------------|---------------------------------|
| Operating voltage | U _B | 12 ... 36 V DC , 12 ... 28 V AC |
| No-load supply current | I ₀ | ≤ 50 mA at 24 V DC |
| Power consumption | P ₀ | ≤ 1 W |

Output

| | | |
|--------------------|------------------------|--|
| Switching type | NO/NC | |
| Signal output | relay, 1 NO | |
| Switching voltage | max. 48 V AC / 48 V DC | |
| Switching current | max. 0.5 A AC / 1 A DC | |
| Switching power | max. 24 W / 60 VA | |
| De-energized delay | t _{off} | 0.2 ... 5 s adjustable (1 sec factory setting) |

Ambient conditions

| | |
|-----------------------|--------------------------------|
| Operating temperature | -20 ... 60 °C (-4 ... 140 °F) |
| Storage temperature | -30 ... 70 °C (-22 ... 158 °F) |
| Relative humidity | max. 90 % non-condensing |

Mechanical specifications

| | |
|-------------------|---|
| Mounting height | max. 4000 mm |
| Protection degree | IP54 |
| Connection | plug-in screw terminals 4-pin , 5 m connecting cable included with delivery |
| Material | |
| Housing | ABS, anthracite |
| Mass | 120 g |
| Dimensions | 123 mm x 65 mm x 57 mm |

Suitable series

| | |
|--------|-----|
| Series | RMS |
|--------|-----|

Functional principle

Microwave sensors are microwave scanners that use the principle of the Doppler radar. The most important requirement for microwave detection is that the object to be detected is moving.

The microwave sensors emit microwaves of a defined frequency in order to detect people and large objects moving at speeds between 100 mm/sec and 5 m/sec.

The microwaves emitted by the emitter are reflected back from the ground or other surfaces to the receiver. If there is no motion in the monitored zone, the emitted and reflected frequencies are identical. Nothing is detected. If people, animals or objects are moving in the monitored zone, the reflected frequency changes and therefore triggers a detection.

Based on the latest 24 GHz technology with integrated microprocessor control, these sensors provide a high degree of reliability even in difficult operating conditions. The 24 GHz frequency, known as the 'K-band,' is reserved by CETECOM for this application area worldwide.

The RMS-D series of sensors are equipped with intelligent functions to enable them to be used in a wide variety of applications. The cross-traffic suppression function is particularly effective in narrow shopping streets and shopping arcades. The system can be configured so that the door opens only when a person approaches it, while ignoring passing pedestrians.

With direction detection, the opening impulse can be triggered based on the direction of motion. Depending on the setting, only movements towards or away from the sensor are detected. The "slow-motion mode" provides a tangible increase in comfort for senior citizens homes or hospitals. This mode allows detection of extremely slow movements in the direct vicinity of the closing area and can be selectively configured for an open door or a closed door. In the first case, the door is held open when there are slow movements. In the second case, the closed door opens even if a person is approaching so slowly that he would not be recognized by normal motion detection devices.

Typical applications

- Opening impulse sensor for automatic and industrial doors
- Monitoring approach areas to automatic doors and elevators
- Motion sensor for people and objects
- Impulse sensor for escalators
- Opening impulse sensor for entry doors

Detection area



Accessories

RMS Remote Control

infrared remote control for series RMS

RMS Weather cap

All-weather hood for RMS series microwave sensors, for ceiling and wall installation

RMS Antenna broad

Radar antenna for wide sensing range

Other suitable accessories can be found at www.pepperl-fuchs.com

Size of the sensing area / sensitivity

The sensitivity potentiometer adjusts the size of the sensing area.

Positioning the sensing area

To adjust the position of the sensor, hold the printed circuit board by its edge, gently pull it forward, then place it in the desired position.

The sensor's position can be adjusted in 5° increments from 0° to 40°.

The default setting from the factory is 15°. Notches can be broken off.

The sensor's printed circuit board can also be inserted at a slant.

Do not angle the board by more than 3 notches from the opposite side!

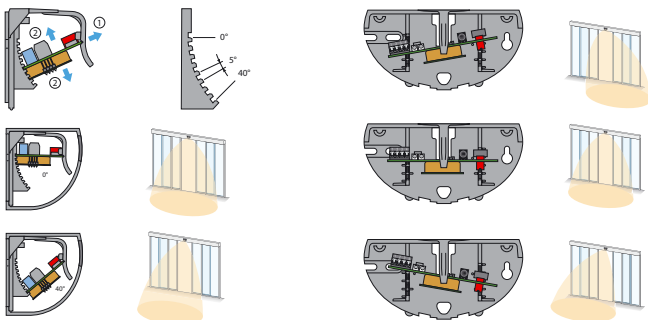

Key to the „Programming the RMS-D“ table

1. Sensing characteristics without direction recognition

forwards / backwards

2. Sensing characteristics with direction recognition

forwards

backwards

3. Masking passing traffic

without masking passing traffic: Door opens with passing traffic

with masking passing traffic: Door remains closed with passing traffic

4. Slowmotion mode

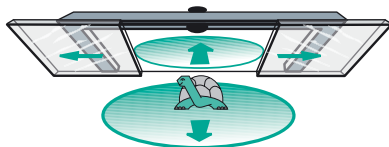

Slowmotion mode door open

If the door is open, the smallest movements are detected. The door only closes if no movement has been detected within the set observation time (1/3/5 seconds). In the case of setting 1 second and 3 seconds, the sensitivity slowly decreases over time (door closes). In the case of setting 5 seconds, the highest sensitivity is permanently used for detection.

Slowmotion mode door close

If an object has approached so slowly that it was not recorded by the normal motion detection, the door opens even when it moves very close to the door.

5. Relay output

Active active the relay output contact is closed when a target is detected

Passive passive the relay output contact is opened when a target is detected

Function display

| | |
|------------------------|--|
| LED green | sensor ready for operation |
| LED red | Recognition |
| LED green flashing | Command received |
| LED red flashing | Error |
| LED green/red flashing | Initialization (10 seconds after power-up) |

Release date: 2012-05-30 17:06 Date of issue: 2012-08-16 18:4850_eng.xml