

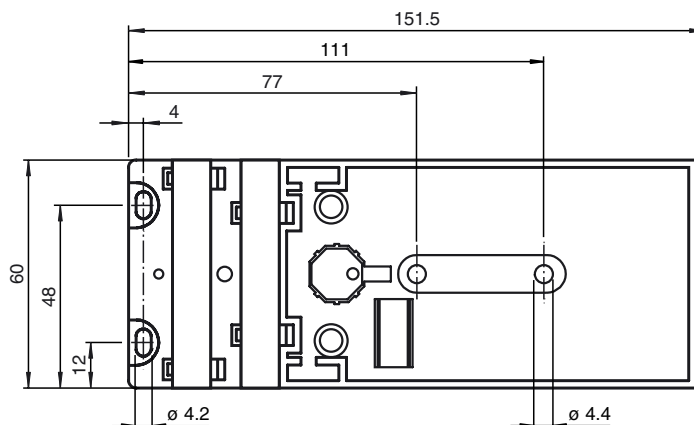

Dimensions



Model Number

U-G2

AS-Interface module mounting base

Function

The base U-G2 is used for mounting G2 modules in long design which are not connected via AS-Interface flat cables.

VBA-4E2A-G2-ZA/EA2-Ex

AS-Interface sensor/actuator module

Technical data

Ambient conditions

Ambient temperature	-25 ... 60 °C (248 ... 333 K)
Storage temperature	-25 ... 70 °C (248 ... 343 K)

Mechanical specifications

Protection degree	IP67 according to EN 60529 (only in connection with module or cover)
-------------------	---

Material

Housing	PBT
Dimensions	about 80, 45, 34 mm (L, W, H)

Notes

Do not connect inputs and outputs, which are supplied via the module from AS-interface or via auxiliary power, with power supply and signal circuits with external potentials.