



Model number

VAA-2E-G2-S
G2 safety module
2 safety-related inputs

Features

- Addressing jack
- Flat cable connection with cable piercing technique, variable flat cable guide
- Communication monitoring
- 2 inputs for mechanical contacts such as EMERGENCY-STOP switch
- Power supply of inputs from the module
- Function display for bus and inputs

Dimensions

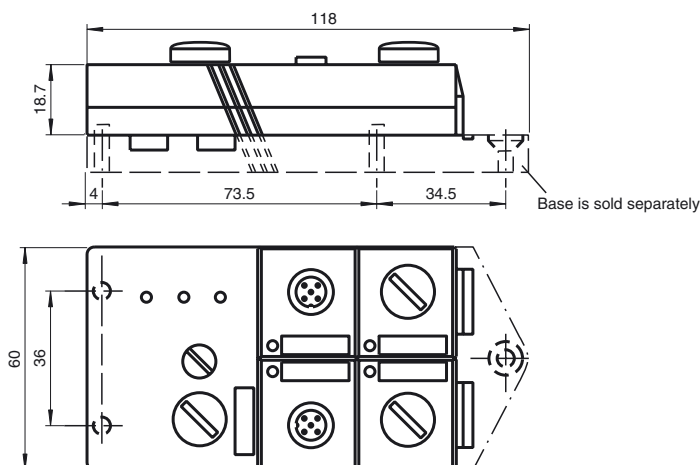

Electrical connection

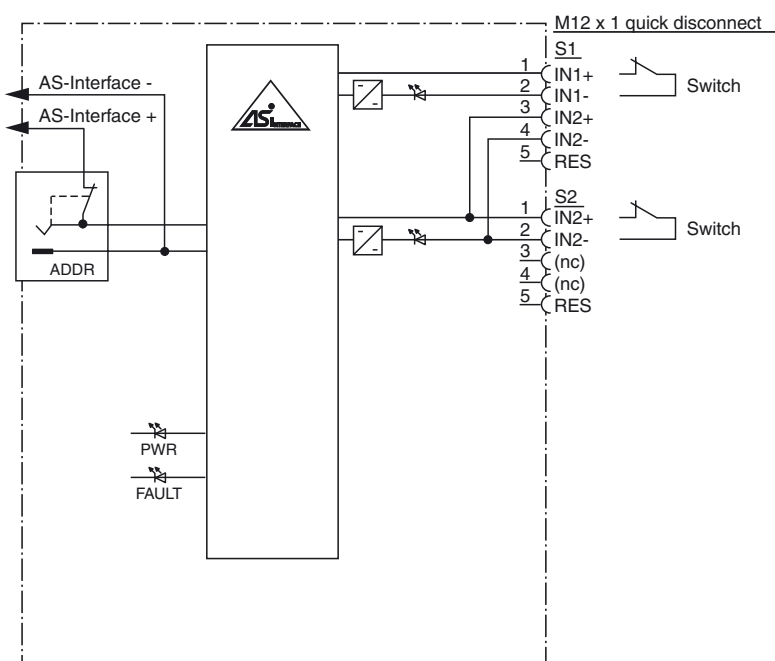

Indicating / Operating means

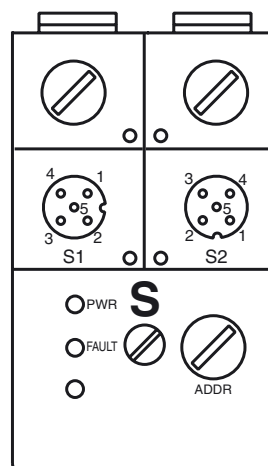

Release date: 2011-06-21 10:59 Date of issue: 2011-06-21 134199_ENG.xml

Technical data**General specifications**

Slave type	Safety-Slave
AS-Interface specification	V2.1
Required master specification	≥ V2.0
UL File Number	E87056

Functional safety related parameters

Safety Integrity Level (SIL)	SIL 3
MTTF _d	200 a

Indicators/operating means

LED FAULT	error display; LED red red: communication error or address is 0
LED PWR	AS-Interface voltage; LED green
LED IN	switching state (input); 2 LED yellow

Electrical specifications

Rated operational voltage	U _e	26.5 ... 31.6 V PELV from AS-Interface
Rated operational current	I _e	≤ 70 mA
Protection class		III

Input

Number/Type	2 safety-related inputs for mechanical contacts, cross-circuit monitored: 2 single-channel contacts: up to category 2 in accordance with EN 954-1 or 1, 2-channel contact: up to category 4 in accordance with EN 954-1 Cable length must not exceed 30 m per input.
-------------	---

Supply	from AS-Interface
Voltage	20 ... 30 V DC pulsed
Current loading capacity	input current limited ≤ 15 mA, overload and short-circuit resistant

Programming instructions

Profile	S-0.B
IO code	0
ID code	B
ID1 code	F
ID2 code	0

Data bits (function via AS-Interface)	input	output
D0	dyn. safety code 1	-
D1	dyn. safety code 1	-
D2	dyn. safety code 2	-
D3	dyn. safety code 2	-

Parameter bits (programmable via AS-i) function

P0	not used
P1	not used
P2	not used
P3	not used

Ambient conditions

Ambient temperature	-25 ... 55 °C (-13 ... 131 °F)
Storage temperature	-25 ... 85 °C (-13 ... 185 °F)
Shock and impact resistance	15 g, 11 ms in 6 spatial directions 3 shocks 10 g, 16 ms in 6 spatial directions 1000 shocks
Vibration resistance	0.75 mm 10 ... 57 Hz, 5 g 57 ... 150 Hz, 20 cycles

Mechanical specifications

Protection degree	IP67
Connection	Cable piercing method flat cable yellow/flat cable black inputs/outputs: M12 round connector
Material	
Housing	PBT
Mass	100 g
Mounting	Mounting base

Compliance with standards and directives

Directive conformity	
EMC Directive 2004/108/EC	EN 61326, EN 50295, EN 61496-1
Standard conformity	
Electromagnetic compatibility	EN 61000-6-2, EN 61000-4-5 1 kV asymmetric, criterion B, EN 61000-6-4
Emitted interference	EN 61000-6-4:2001
Insulation coordination	EN 50178:1998
Functional safety	EN 954-1:1996 (up to category 4), BIA Final Draft "Proposal for a principle to the verification and certification of field busses for transmission of safety related signals" 28.05.2000, IEC 61508 up to SIL3
Protection degree	EN 60529:2000
Fieldbus standard	EN 50295:1999, IEC 62026-2:2006
Electrical safety	EN 60947-5-1:2005, IEC 60204-1:2007

Function

The VAA-2E-G2-S is an AS-Interface safety module with 2 safety-related inputs. A dual channel mechanical switch or in each case a single channel mechanical switch can be connected to the two inputs.

The IP67 flat module features an integrated addressing jack and is ideal for applications in the field.

The connection to the switches is set up by means of M12 x 1-screw connections. The current switching state of each channel is indicated by an LED, located on the module's top side. Similarly, an LED is provided to monitor the AS-Interface communication and to indicate that the module has the address 0.

When single channel force-directed mechanical switches are connected, up to Category 2 in accordance with EN 954-1 can be achieved, given the appropriate wiring and selection of switch.

When a two-channel force-directed mechanical switch is connected, up to Category 4 in accordance with EN 954-1 can be achieved, given the appropriate wiring and selection of switch.

Both inputs of the module are assigned. The two channels of the mechanical switch are monitored for a cross circuit. LEDs are also provided to indicate AS-Interface voltage and external power supply.

As per approval in accordance with IEC 61508 up to SIL 3 can be achieved.

The U-G3FF mounting base is normally used for the connection of the AS-Interface flat cable and the external sensor power supply. The specially designed base enables the user to connect flat cables from both sides.

Note:

The mounting base for the module is sold separately.

Accessories**V1-CLIP**

Interlock protection for M12 connector

VBP-HH1-V3.0

AS-Interface Handheld

VAZ-PK-1,5M-V1-G

Connection cable module/hand-held programming device

VAZ-FK-ED-G2

AS-Interface end seal for G2 modules

Matching system components**U-G3FF**

AS-Interface module mounting base for connection to flat cable (AS-Interface and external auxiliary power)

Standards

NFPA 79:2002

Notes

The cables and the way they are laid must comply with the standards that apply to the application, e. g. IEC 60204. The requirements specified in the instructions must be observed.

Do not connect inputs and outputs, which are supplied via the module from AS-interface or via auxiliary power, with power supply and signal circuits with external potentials.

Release date: 2011-06-21 10:59 Date of issue: 2011-06-21 134199_ENG.xml

Subject to modifications without notice

Pepperl+Fuchs Group
www.pepperl-fuchs.com

USA: +1 330 486 0001
fa-info@us.pepperl-fuchs.com

Germany: +49 621 776-4411
fa-info@pepperl-fuchs.com

Copyright Pepperl+Fuchs
Singapore: +65 6779 9091
fa-info@sg.pepperl-fuchs.com