

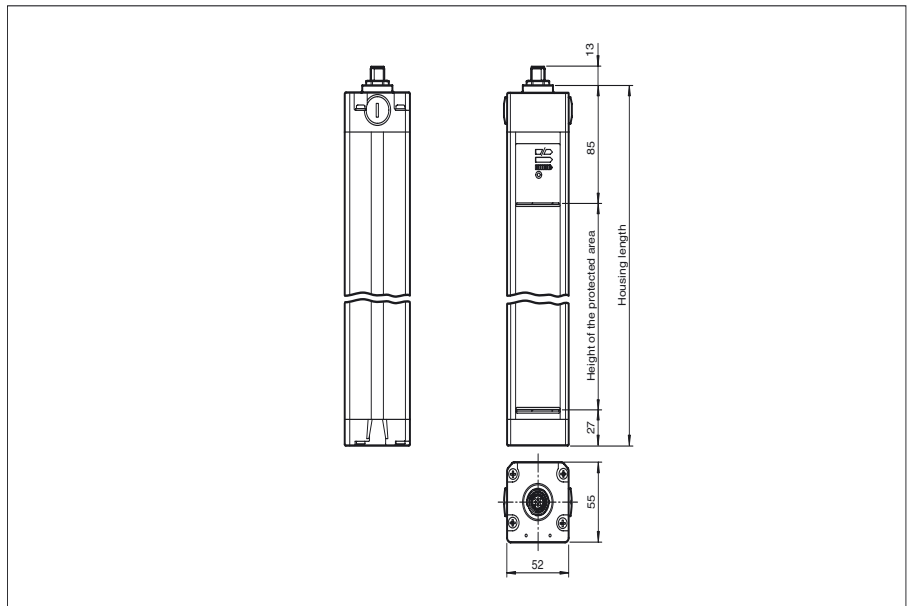

**Dimensions**



**Model Number**

**SLC14-1800/129/130**

with 2 separate fail-safe semiconductor outputs

**Features**

- Sensing range up to 5 m
- Resolution 14 mm (finger protection)
- Protective field height up to 1800 mm
- Self-monitoring (type 4 according to IEC/EN 61496-1)
- Master/Slave detection, Plug and Play
- Very short response time
- Protection degree IP67
- Integrated function display
- Pre-fault indication
- Safety outputs OSSD in potential-separated semiconductor version
- Start/Restart disable preset by Option /129
- Integrated relay monitor

**Accessories**

**PG SLC-1800**  
Protective glass panes for SLC series

**BA SLC**  
laser alignment aid for safety light curtains series SLC

**Electrical connection**

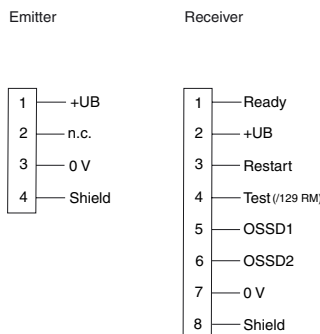

**Pinout**

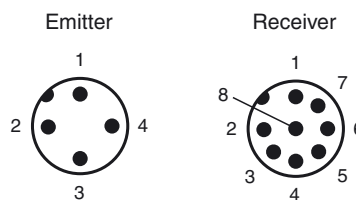

Release date: 2012-08-01 11:48 Date of issue: 2012-08-01 12:045\_eng.xml

**Technical data****General specifications**

Effective detection range	0.2 ... 5 m
Light source	IREDD
Light type	modulated infrared light
Approvals	TÜV, cULus
Tests	IEC/EN 61496
Safety type according to IEC/EN 61496	4
Marking	CE
Width of protected area	0.2 ... 5 m
Protection field height	1800 mm
Number of beams	192
Operating mode	Startup/restart disable preset with Relay monitor (preset)
Optical resolution	14 mm
Angle of divergence	< 5 °

**Functional safety related parameters**

Safety Integrity Level (SIL)	SIL 3
Performance level (PL)	PL e
Category	Cat. 4
Mission Time (T <sub>M</sub> )	20 a
PFH <sub>d</sub>	2.28 E-8
Type	4

**Indicators/operating means**

Operating display	7-segment display in emitter
Diagnostics display	7-segment display in receiver
Function display	in receiver: LED red: OSSD off LED green: OSSD on LED yellow: Protected area free, system start-ready
Pre-fault indication	LED orange
Controls	Transmission coding

**Electrical specifications**

Operating voltage	U <sub>B</sub>	24 V DC (-30 %/+25 %)
No-load supply current	I <sub>0</sub>	Emitter: ≤ 100 mA receiver: ≤ 150 mA
Protection class		III

**Input**

Activation current	approx. 10 mA
Activation time	0.03 ... 1 s
Function input	Start release

**Output**

Safety output	2 separated fail safe semiconductor outputs
Signal output	1 PNP, max. 100 mA for start readiness
Switching voltage	Operating voltage -2 V
Switching current	max. 0.5 A
Response time	36 ms

**Ambient conditions**

Ambient temperature	0 ... 55 °C (32 ... 131 °F)
Storage temperature	-25 ... 70 °C (-13 ... 158 °F)
Relative humidity	max. 95 %, not condensing

**Mechanical specifications**

Housing length L	1910 mm
Protection degree	IP67
Connection	Emitter: terminal compartment with screw terminals, lead cross-section max. 1.5 mm <sup>2</sup> Receiver: terminal compartment with screw terminals, lead cross-section max. 1.5 mm <sup>2</sup>
Material	
Housing	extruded aluminum profile, RAL 1021 (yellow) coated
Optical face	Plastic pane
Mass	Per 5700 g

**General information**

System components	
Emitter	SLC14-1800-T/130
Receiver	SLC14-1800-R/129/130

**Compliance with standards and directives**

Directive conformity	
Machinery Directive 2006/42/EC	EN ISO 13849-1:2008 EN 61496-1:2004/A1:2008
EMC Directive 2004/108/EC	EN 61000-6-4:2007 + A1:2011
Standard conformity	
Standards	IEC 61496-2:2006 EN 50178:1997

**Approvals and certificates**

CE conformity	CE
UL approval	cULus Listed
CCC approval	Products with a maximum operating voltage of ≤36 V do not bear a CCC marking because they do not require approval.
TÜV approval	TÜV

Curves/Diagrams

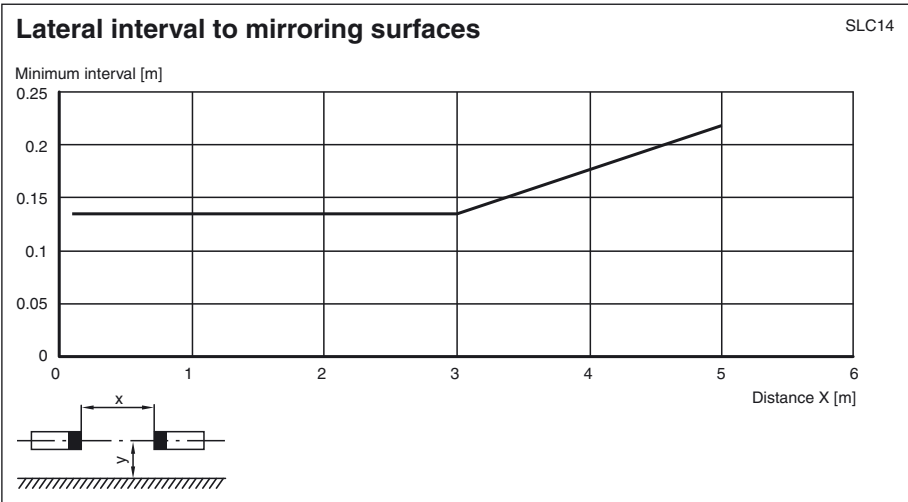
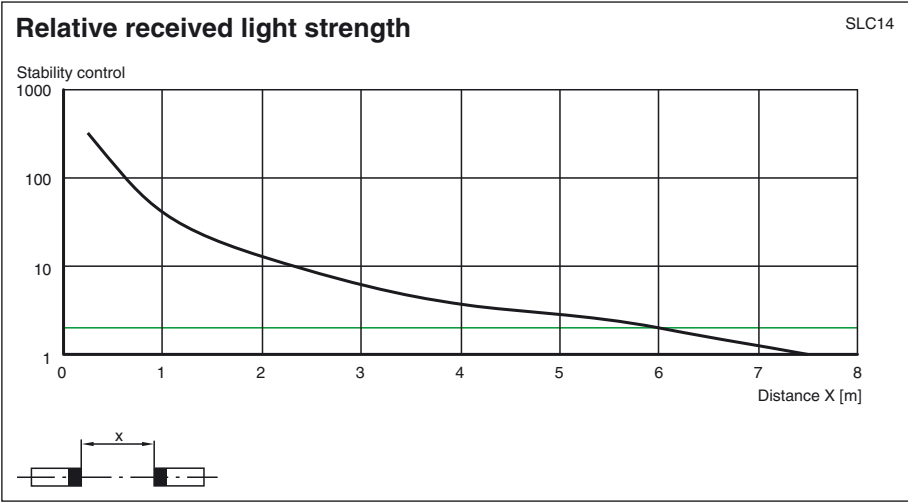
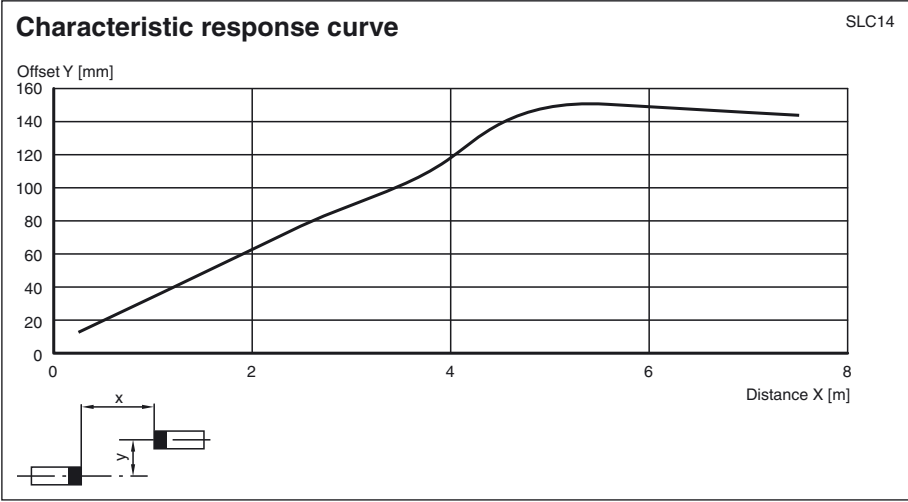

**Note**

**Master-Slave operation**

- Master: SLC... (semiconductor)  
or SLC.../31 (relay)
- Slave: SLC...-S

Release date: 2012-08-01 11:48 Date of issue: 2012-08-01 126045\_eng.xml

Subject to modifications without notice

Pepperl+Fuchs Group  
www.pepperl-fuchs.com

USA: +1 330 486 0001  
fa-info@us.pepperl-fuchs.com

Germany: +49 621 776-4411  
fa-info@pepperl-fuchs.com

Copyright Pepperl+Fuchs

Singapore: +65 6779 9091  
fa-info@sg.pepperl-fuchs.com

The use of slaves allows both the protection fields to be extended and protection fields to be created that do not all exist at a single level. When deciding which slaves to connect, remember that the total maximum of 96 beams must not be exceeded. Up to 192 beams are possible if the /130 option is selected.

Slaves exist for the transmitter and the receiver. These simply need to be connected to the master light curtain. Up to two slaves can be connected to both the transmitter and receiving units. Only one slave can be connected if the /130 option is selected.

Installation:

- 1 The end cap (no cable gland) on the light curtain is unscrewed and removed.
- 2 The plug-in jumper on the connectors of the now visible PCB is removed.
- 3 The slave is designed in such a way that the cap and PCB on the connecting cable plug directly onto the open end of the light curtain.
- 4 Once the end cap has been screwed on, the system is complete.

## System accessories

- Mounting set SLC
- Test rods SLC14/SLC30/SLC60
- Protection glass for SLC (to protect the optical surface)
- Side cable gland SLC
- Profile alignment tool
- Beam alignment tool SLC
- Mirror for SLC (to protect danger areas on more than one side)
- Stands UC SLP/SLC
- Enclosure for stands  
Enclosure UC SLP/SLC
- Start protection  
Damping UC SLP/SLC