



Model Number

NJ5-18GM-N-Y125585

Features

- Comfort series
- 5 mm embeddable

Connection

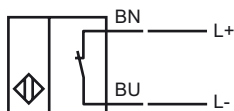

Accessories

EXG-18

Quick mounting bracket with dead stop

Dimensions

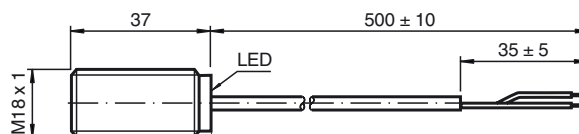

Technical Data

General specifications

Switching element function		NAMUR, NC
Rated operating distance	s_n	5 mm
Installation		embeddable
Output polarity		NAMUR
Assured operating distance	s_a	0 ... 4.05 mm
Reduction factor r_{Al}		0.21
Reduction factor r_{Cu}		0.18
Reduction factor r_{V2A}		0.63

Nominal ratings

Nominal voltage	U_o	8 V
Switching frequency	f	0 ... 500 Hz
Hysteresis	H	0.1 ... 0.2 mm

Output signal

Switching state OFF	Switch not actuated: $U_R < 1$ V
Switching state ON	Switch actuated: $U_R > 2.7$ V
Indication of the switching state	LED red switch actuated: LED off switch not actuated: LED on

Ambient conditions

Ambient temperature	-25 ... 70 °C (-13 ... 158 °F)
---------------------	--------------------------------

Mechanical specifications

Connection type	cable PVC, 500 mm
Core cross-section	2 x 0.34 mm ²
Housing material	brass, nickel-plated
Sensing face	PBT
Protection degree	IP67

Approvals and certificates

UL approval	cULus Listed, General Purpose
CSA approval	cCSAus Listed, General Purpose

Installation hint

possible sensor interface

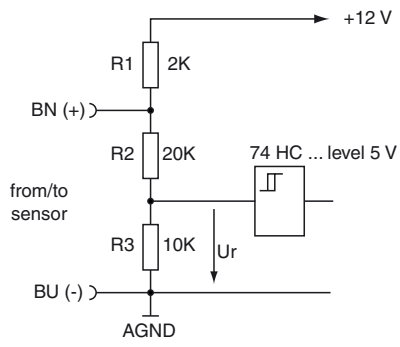

Release date: 2010-11-04 10:15 Date of issue: 2010-11-04 125585_ENG.xml