

Comfort series  
50 mm not embeddable

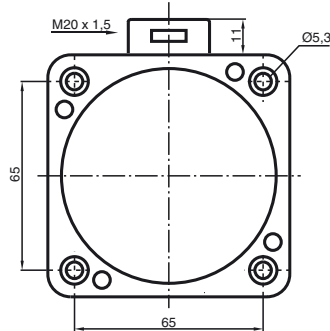
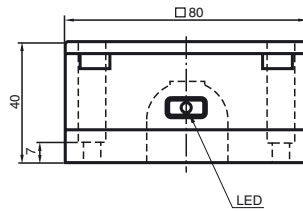

CE

General specifications	
Switching element function	PNP Antivalent
Rated operating distance $s_n$	50 mm
Installation	not embeddable
Output polarity	DC
Assured operating distance $s_a$	0 ... 40.5 mm
Reduction factor $r_{AI}$	0.4
Reduction factor $r_{Cu}$	0.3
Reduction factor $r_{V2A}$	0.85
Nominal ratings	
Operating voltage $U_B$	10 ... 60 V
Switching frequency $f$	0 ... 100 Hz
Hysteresis $H$	typ. 3 %
Reverse polarity protection	protected against reverse polarity
Short-circuit protection	pulsing
Voltage drop $U_d$	$\leq 3$ V
Operating current $I_L$	0 ... 200 mA
Off-state current $I_r$	0 ... 0.5 mA typ.
No-load supply current $I_0$	$\leq 20$ mA
Operating voltage display	LED, green
Indication of the switching state	LED, yellow
Standard conformity	
Standards	IEC / EN 60947-5-2:2004
Ambient conditions	
Ambient temperature	-25 ... 70 °C (248 ... 343 K)
Mechanical specifications	
Connection type	terminal compartment
Core cross-section	up to 2.5 mm <sup>2</sup>
Housing material	PBT
Sensing face	PBT
Protection degree	IP67
General information	
Use in the hazardous area	see instruction manuals
Category	3G; 3D

### Connection type:

A2

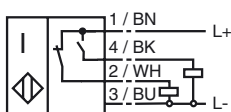

## ATEX 3G (nA)

Instruction

### Device category 3G (nA)

Directive conformity

Standard conformity

CE symbol

Ex-identification

General

Installation, Commissioning

Maintenance

Special conditions

Maximum operating current  $I_L$

Maximum operating voltage  $U_{Bmax}$

Maximum permissible ambient temperature  $T_{Umax}$

at  $U_{Bmax}=60\text{ V}$ ,  $I_L=200\text{ mA}$

at  $U_{Bmax}=30\text{ V}$ ,  $I_L=200\text{ mA}$

at  $U_{Bmax}=30\text{ V}$ ,  $I_L=100\text{ mA}$

Plug connector

Protection from mechanical danger

Protection from UV light

Connections for external wire

Lead insertion

## Manual electrical apparatus for hazardous areas

for use in hazardous areas with gas, vapour and mist

94/9/EG

EN 60079-15:2003

Ignition protection category "n"

Use is restricted to the following stated conditions

CE

II 3G EEx nA IIC T6 X

The apparatus has to be operated according to the appropriate data in the data sheet and in this instruction manual.

The data stated in the data sheet are restricted by this operating instruction! The special conditions must be observed!

Laws and/or regulations and standards governing the use or intended usage goal must be observed.

No changes can be made to apparatus, which are operated in hazardous areas. Repairs to these apparatus are not possible.

The maximum permissible load current must be restricted to the values given in the following list. High load currents and load short-circuits are not permitted.

The maximum permissible operating voltage  $U_{Bmax}$  is restricted to the values in the following list. Tolerances are not permissible.

dependant of the load current  $I_L$  and the max. operating voltage  $U_{Bmax}$ .

Information can be taken from the following list.

45 °C

49 °C

54 °C

The plug connector must not be disconnected under voltage. The proximity switch is marked as follows: "DO NOT DISCONNECT UNDER VOLTAGE!" When the plug connector is disconnected the ingress of dirt into the inner areas (i.e. the areas, which are not accessible in the plugged-in condition) must be prevented.

The sensor must not be exposed to **ANY FORM** of mechanical danger.

The sensor and the connection cable must be protected from damaging UV-radiation. This can be achieved when the sensor is used in internal areas.

Terminal connection: Minimum conductor cross-section: 0.5 mm<sup>2</sup>, maximum conductor cross-section: 2.5 mm<sup>2</sup>. The ends of the conductor must be provided with cable sleeves.

The cable entry must be such, that no tension load or twist is applied to the cable

The protection category must be in accordance with EN 60529 and as stated in the data sheet. The cable entry must be designed so that there are no sharp edges to damage the cable and impair the level of protection of the sensor. The cable entry must be in accordance with the relevant European standard for industrial cable and lead entries.. In addition, in the case of flexible leads, the points of entry of the cable must be rounded off over an angle of at least 75°, with a radius (R), which is at least one quarter of the maximum permissible cable diameter for the entry, but not greater than 3 mm.

## ATEX 3D

Instruction

### Device category 3D

Directive conformity  
Standard conformity

CE symbol

Ex-identification

General

Installation, Commissioning

Maintenance

[Fett]Special conditions

Maximum operating current  $I_L$

Maximum operating voltage  $U_{Bmax}$

Maximum heating (Temperature rise)

at  $U_{Bmax}=60\text{ V}$ ,  $I_L=200\text{ mA}$

at  $U_{Bmax}=30\text{ V}$ ,  $I_L=200\text{ mA}$

at  $U_{Bmax}=30\text{ V}$ ,  $I_L=100\text{ mA}$

Plug connector

Protection from mechanical danger

Electrostatic charging

Connections for external wire

Lead insertion

## Manual electrical apparatus for hazardous areas

for use in hazardous areas with non-conducting combustible dust  
94/9/EG

EN 50281-1-1

Protection via housing

Use is restricted to the following stated conditions

CE

Ex II 3D IP67 T 94 °C X

The apparatus has to be operated according to the appropriate data in the data sheet and in this instruction manual.

The data stated in the data sheet are restricted by this operating instruction! The special conditions must be adhered to!

Laws and/or regulations and standards governing the use or intended usage goal must be observed.

No changes can be made to apparatus, which are operated in hazardous areas. Repairs to these apparatus are not possible.

The maximum permissible load current must be restricted to the values given in the following list.

High load currents and load short-circuits are not permitted.

The maximum permissible operating voltage  $U_{Bmax}$  must be restricted to the values given in the following list. Tolerances are not permitted.

dependant of the load current  $I_L$  and the max. operating voltage  $U_{Bmax}$ .

Information can be taken from the following list. The maximum surface temperature at maximum ambient temperature is given in the Ex identification of the apparatus.

24 °C

21 °C

15 °C

The plug connector must not be disconnected under voltage. The proximity switch is marked as follows: "DO NOT DISCONNECT UNDER VOLTAGE!" When the plug connector is disconnected the ingress of dirt into the inner areas (i.e. the areas, which are not accessible in the plugged-in condition) must be prevented.

The sensor must not be mechanically damaged.

Sliding contact discharges must be avoided.

Terminal connection: Minimum conductor cross-section: 0.5 mm<sup>2</sup>, maximum conductor cross-section: 2.5 mm<sup>2</sup>. The ends of the conductor must be provided with cable sleeves.

The cable entry must be such, that no tension load or twist is applied to the cable

The protection category must be in accordance with EN 60529 and as stated in the data sheet. The cable entry must be designed so that there are no sharp edges to damage the cable and impair the level of protection of the sensor. The cable entry must be in accordance with the relevant European standard for industrial cable and lead entries. In addition, in the case of flexible leads, the points of entry of the cable must be rounded off over an angle of at least 75°, with a radius (R), which is at least one quarter of the maximum permissible cable diameter for the entry, but not greater than 3 mm.