



Model Number

PLVScanP24-1116-48/47/86

Light grid
with terminal compartment

Features

- Measuring light grid
- Beam spacing 48.5 mm
- RS 232 interface for data transmission and configuration
- Adjustable beam crossover and emitted optical power
- Separate outputs for height monitoring
- Programmable via Windows software

Dimensions

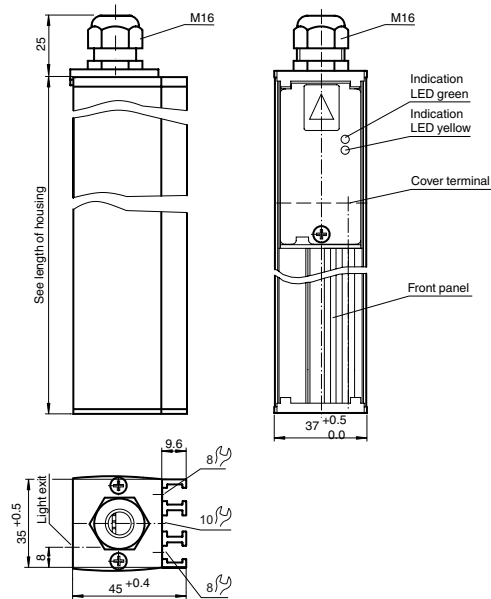

Electrical connection

Emitter

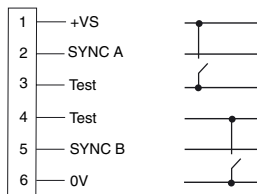

Receiver

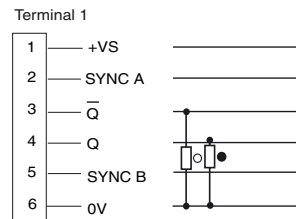

Terminal 2

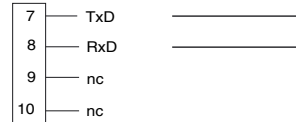

○ = Light on
● = Dark on

Technical data**General specifications**

Effective detection range	3 ... 8 m , can be reduced to > 0.3 m
Threshold detection range	12 m
Sensing range	0 ... 8000 mm
Light source	IREL
Light type	modulated infrared light
Field height	1116 mm
Chipping	5X
Beam spacing	48.5 mm
Number of beams	24
Angle of divergence	Emitter: $\pm 13^\circ$, Receiver: $\pm 8^\circ$
Ambient light limit	50000 Lux

Indicators/operating means

Operating display	LED green
Function display	Emitter: LED yellow, light with free light beam, off when falling short of the function reserve , Receiver: LED yellow: flashes when the beam field is interrupted, otherwise off
Controls	Potentiometer for adjustment of the transmitting power (in the terminal compartment)

Electrical specifications

Operating voltage	U_B	20 ... 30 V DC
Ripple		10 %
Power consumption	P_0	max. 10 W

Interface

Interface type	RS 232
----------------	--------

Input

Test input	emitter deactivation with $+U_B$ on terminal 3 or 0V on terminal 4
Function input	RS 232 interface for system programming

Output

Switching type	light/dark on	
Signal output	2 PNP, complementary, short-circuit protected (monitoring field) and 1 x RS 232 interface with serial data output	
Switching voltage	30 V DC	
Switching current	200 mA	
Switching frequency	f	20 Hz
Response time	24 ms without crossing of beams	
Timer function	Off-delay programmable from 0 ... 1.25 s in 5 ms steps	

Ambient conditions

Ambient temperature	-10 ... 60 °C (14 ... 140 °F) In North America: -10 ... 40 °C (14 ... 104 °F)
Storage temperature	-20 ... 70 °C (-4 ... 158 °F)

Mechanical specifications

Housing length L	2427 mm
Protection degree	IP50
Connection	PG9 terminal compartment with screw terminals
Material	
Housing	silver-anodized aluminum
Optical face	PMMA
Mass	1600 g (device)

Compliance with standards and directives

Standard conformity	
Product standard	EN 60947-5-2:2007 IEC 60947-5-2:2007

Approvals and certificates

CE conformity	yes
UL approval	cULus
CCC approval	Products with a maximum operating voltage of ≤ 36 V do not bear a CCC marking because they do not require approval.

Curves/Diagrams

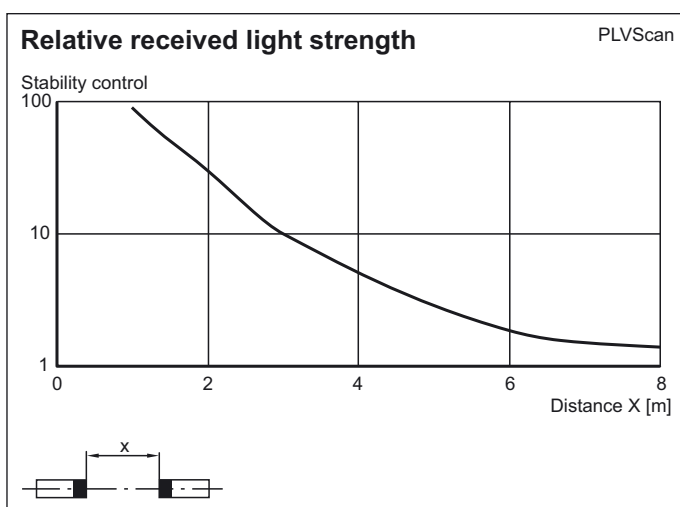
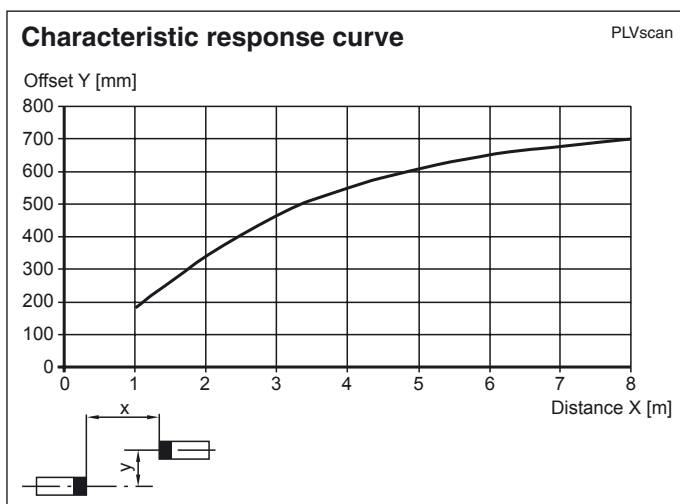

Arrangement and function

Principle of operation

Light grids consist of an emitter bar and a receiver bar. The surface to be monitored is in between the two. The switching command is initiated by a body or object penetrating into the monitoring field.

The light grid PLVScan ensures an overall monitoring of the evaluation range with a max. of 64 light beams (infrared emitter and receiver). The integrated signal processing saves an additional mounting of a separate controlgear. Due to the modular design of the system, different distances of the light beams can be implemented. This makes it possible to use the light grids of the PLVScan series optimally and adapt them specifically to a given application.

In addition the system is equipped with up to four switch outputs which can be used for height monitoring (option /139) or with a serial data output across which the state of the beams can be queried(option /86). The system programming is accomplished via a RS 232 interface. For this purpose, the software WINPLV is required which can be ordered separately.

Safety Instructions:

The device must only be operated with an extra-low safety voltage with safe electrical separation. Only your supplier is authorised to make repairs or changes to the device!

The system must be regularly maintained and monitored. The programming cable can only be plugged in when the light grid is turned on and working correctly.

A clean, soft cloth can be used for cleaning. Aggressive, abrasive and scratching cleaners that could scour or damage the surface must be avoided. The device must not be exposed to strong jolts or vibrations.

Commissioning

Preconditions:

- The emitter and receiver bars must be correctly mounted and aligned.
- The electrical connection must have been set up according to the connection diagram.
- **Important:** The sync lines must be connected to each other (A to A) and (B to B).
- The signal output responds to object detection or heavy accumulation of dirt and dust on the transparent outline covering.
- In the case of interruption of at least one light beam, the output remains active as long as the object or the soiling is detected.



Representation of the course of the beam as straight/crossed, design example with three light lines for height monitoring

Release date: 2011-09-20 17:00 Date of issue: 2011-09-20 123533_eng.xml

Subject to modifications without notice

Pepperl+Fuchs Group
www.pepperl-fuchs.com

USA: +1 330 486 0001
fa-info@us.pepperl-fuchs.com

Germany: +49 621 776-4411
fa-info@pepperl-fuchs.com

Copyright Pepperl+Fuchs
Singapore: +65 6779 9091
fa-info@sg.pepperl-fuchs.com