

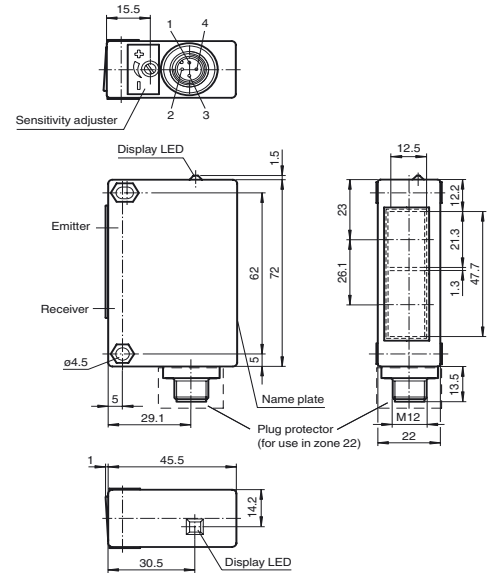

**Dimensions**

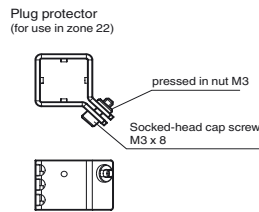

**Model Number**

**RL32-8-H-800-Ex2/47/73c**

Background suppression sensor with 4-pin, M12 x 1 plastic connector

**Features**

- ATEX-approval for zone 2 and zone 22
- Sleek design, especially for storage and conveyor systems
- Adjustable background suppression
- Excellent optical performance data
- Scratch-resistant and solvent resistant glass lens

**Electrical connection**

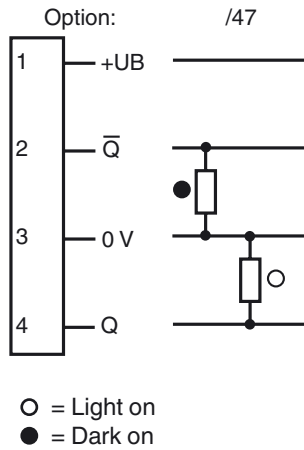

**Pinning according**

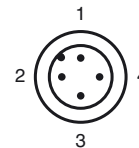

Release date: 2012-07-06 13:25 Date of issue: 2012-08-07 12:1162\_eng.xml

**Technical data****General specifications**

Detection range	30 ... 800 mm
Detection range min.	30 ... 300 mm
Detection range max.	30 ... 800 mm
Reference target	standard white 200 mm x 200 mm
Light source	IRED
Light type	modulated infrared light
Black/White difference (6%/90%)	< 15 %
Diameter of the light spot	approx. 25 mm at 800 mm sensor range
Angle of divergence	approx. 3 °
Ambient light limit	80000 Lux

**Functional safety related parameters**

MTTF <sub>d</sub>	840 a
Mission Time (T <sub>M</sub> )	20 a
Diagnostic Coverage (DC)	0 %

**Indicators/operating means**

Function display	LED yellow, lights up with receiver lit
Controls	Detection range adjuster

**Electrical specifications**

Operating voltage	U <sub>B</sub>	10 ... 30 V DC
Ripple		10 %
No-load supply current	I <sub>0</sub>	40 mA

**Output**

Switching type	light/dark on	
Signal output	2 PNP, complementary, short-circuit protected, reverse polarity protected	
Switching voltage	30 V DC	
Switching current	max. 50 mA	
Switching frequency	f	250 Hz
Response time		2 ms

**Ambient conditions**

Ambient temperature	-20 ... 50 °C (-4 ... 122 °F)
Storage temperature	-20 ... 60 °C (-4 ... 140 °F)

**Mechanical specifications**

Protection degree	IP65
Connection	Plastic connector M12 x 1, 4-pin
Material	
Housing	Terluran GV15
Optical face	glass
Mass	60 g

**General information**

Use in the hazardous area	see more details for the use in hazardous areas
Category	3G; 3D

**Compliance with standards and directives**

Directive conformity	
EMC Directive 2004/108/EC	EN 60947-5-2:2007
Standard conformity	
Product standard	EN 60947-5-2:2007 IEC 60947-5-2:2007

**Approvals and certificates**

CCC approval	Products with a maximum operating voltage of ≤36 V do not bear a CCC marking because they do not require approval.
--------------	--

**ATEX 3G (nA)**

Instruction

**Manual electrical apparatus for hazardous areas****Device category 3G (nA)**

for use in hazardous areas with gas, vapour and mist

Directive conformity

94/9/EG

Standard conformity

EN 60079-0:2009 , EN 60079-15:2010 , EN 60079-28:2007

Ex-identification

Ⓔ II 3 G Ex nAc op is IIC T4

Installation, Commissioning

Laws and/or regulations and standards governing the use or intended usage goal must be observed. Attach the connector fuse provided so that the connector cannot be unplugged without using tools. Only connections that are disconnected from the power supply may be unplugged.

Maintenance

No modifications must be undertaken on apparatus, which is operated in hazardous areas. Repairs to such apparatus are not permissible.

**Special conditions**Maximum permissible ambient temperature T<sub>Umax</sub>

50 °C (122 °F)

Protection from mechanical danger

The apparatus must be protected from mechanical damage.

Protection from UV light

The sensor must be protected against harmful UV radiation. This can be achieved by using the sensor indoors.

Protection of overvoltage

Precautions must be taken to prevent the rated voltage being exceeded by more than 40 % due to transient disturbances.

Protect from direct sunlight  
Other conditions

Set up the apparatus so that optical components cannot come into contact with direct sunlight.  
The optical light from the emitter must not be focused. The plug connector must not be disconnected under voltage. When the plug connector is disconnected the ingress of dirt into the inner areas (i.e. the areas, which are not accessible in the plugged-in condition) must be prevented. The plug connection can only be separated using a tool. This is achieved by using the unlocking protection "Plug protector" (Mounting accessory from Pepperl + Fuchs).

**ATEX 3D**

Instruction

**Manual electrical apparatus for hazardous areas**

Details for use in hazardous areas

Electrical apparatus for potentially explosive atmospheres

Directive conformity

94/9/EG

Standard conformity

EN 60079-31:2009

Ex-identification

Ⓔ II 3 D Ex tc IIIC T75 °C

Installation, Commissioning

Laws and/or regulations and standards governing the use or intended usage goal must be observed. Attach the connector fuse provided so that the connector cannot be unplugged without using tools. Only connections that are disconnected from the power supply may be unplugged.

Maintenance

No modifications must be undertaken on apparatus, which is operated in hazardous areas. Repairs to such apparatus are not permissible.

**Special conditions**

Protection from mechanical danger

The apparatus must be protected from mechanical damage.

Protection from UV light

The sensor must be protected against harmful UV radiation. This can be achieved by using the sensor indoors.

Protection of overvoltage

Precautions must be taken to prevent the rated voltage being exceeded by more than 40 % due to transient disturbances.

Other conditions

Set up the apparatus so that optical components cannot come into contact with direct sunlight.

**Curves / Diagrams**

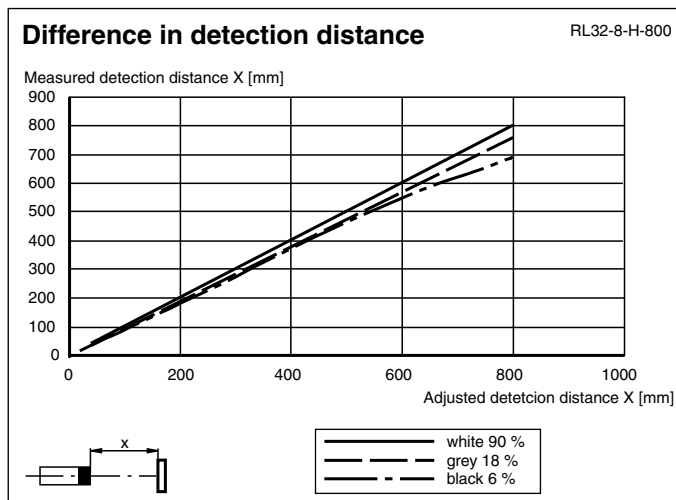
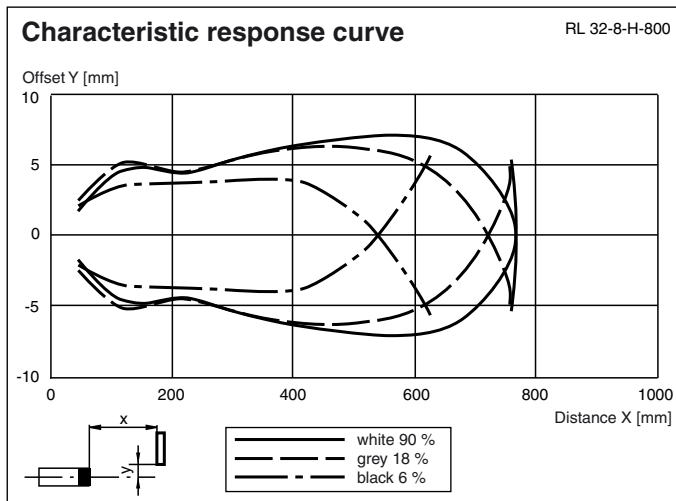

Release date: 2012-07-06 13:25 Date of issue: 2012-08-07 12:1162\_eng.xml