

Model Number

RL28-54-G-Z/47/116

Retroreflective sensor
with terminal compartment

Features

- Detects transparent objects, i.e., clear glass, PET and transparent films
- TEACH-IN switch for setting the contrast detection levels
- Automatic adjustment in case of soiling in contrast detection mode
- Ultra bright LEDs for power on, pre fault indication and switching state
- Flashing power on LED in case of short-circuit
- Not sensitive to ambient light, even with energy saving lamps
- Impulsed time element off-delay
- Waterproof, protection degree IP67
- Protection class II

Dimensions

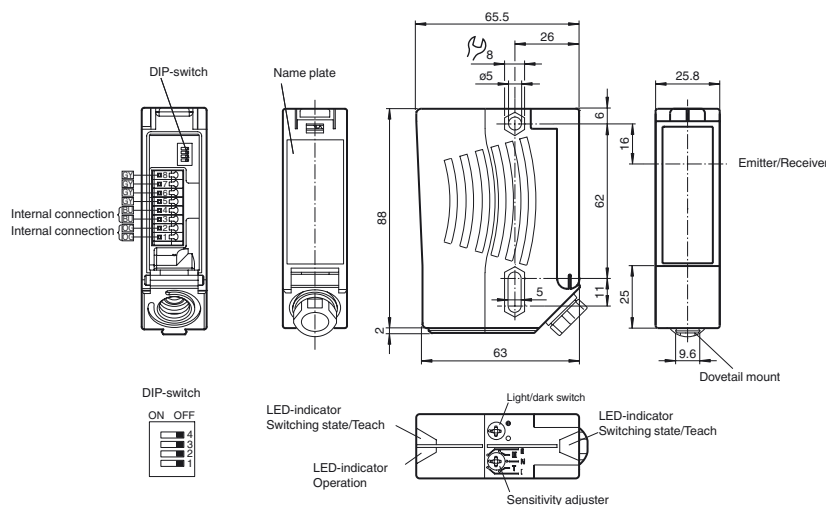

Electrical connection

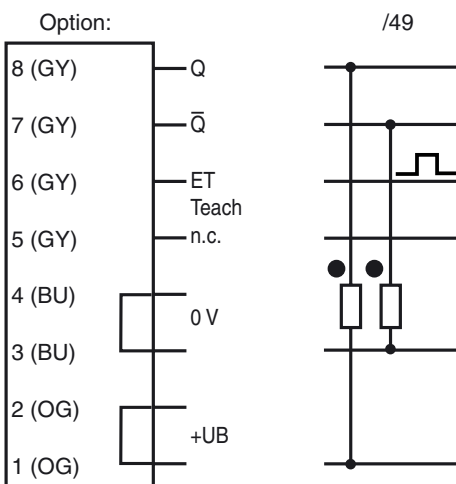

- = Light on
- = Dark on

Release date: 2011-12-21 10:24 Date of issue: 2011-12-21 116635_eng.xml

Subject to modifications without notice

Pepperl+Fuchs Group
www.pepperl-fuchs.com

USA: +1 330 486 0001
fa-info@us.pepperl-fuchs.com

Germany: +49 621 776-4411
fa-info@pepperl-fuchs.com

Copyright Pepperl+Fuchs
Singapore: +65 6779 9091
fa-info@sg.pepperl-fuchs.com

Technical data**General specifications**

Effective detection range	0 ... 5.6 m
Reflector distance	0 ... 5.6 m
Threshold detection range	7 m

Reference target	H85-2 reflector
Light source	LED
Light type	modulated visible red light , 660 nm
Diameter of the light spot	approx. 90 mm at a distance of 5.6 m
Angle of divergence	Emitter: 1 ° Receiver: 1.2 °
Ambient light limit	50000 Lux

Functional safety related parameters

MTTF _d	1020 a
Mission Time (T _M)	20 a
Diagnostic Coverage (DC)	0 %

Indicators/operating means

Operating display	LED green, flashes in case of short-circuit
Function display	2 LEDs yellow for switching state, stability control, TEACH-IN and contrast detection mode
Controls	rotary switch for light/dark, 5-step switch for contrast recognition adjustment
Contrast detection levels	10 % - clean, water filled PET bottles 18 % - clear glass bottles 40 % - colored glass or opaque materials adjustable by TEACH-IN key or external wire

Electrical specifications

Operating voltage	U _B	10 ... 30 V DC
Ripple		10 %
No-load supply current	I ₀	≤ 50 mA

Input

Function input	Ext. Teach-In input (ET)
----------------	--------------------------

Output

Switching type	light/dark on switchable	
Signal output	2 PNP, complementary, short-circuit protected, reverse polarity protected , open collectors	
Switching voltage	max. 30 V DC	
Switching current	max. 200 mA	
Voltage drop	U _d	≤ 2.5 V DC
Switching frequency	f	1000 Hz
Response time		0.5 ms
Timer function		Impulsed time element off-delay 20 ms

Ambient conditions

Ambient temperature	-40 ... 60 °C (-40 ... 140 °F)
Storage temperature	-40 ... 75 °C (-40 ... 167 °F)

Mechanical specifications

Protection degree	IP67
Connection	terminal compartment with 8 spring-loaded terminals for wire cross section 0.5 ... 1.5 mm ² , insulation stripping 7.5 ... 8.5 mm, M16 x 1.5 cable gland
Material	
Housing	Plastic ABS
Optical face	Plastic pane
Mass	90 g

Compliance with standards and directives

Standard conformity	
Product standard	EN 60947-5-2:2007

Approvals and certificates

Protection class	II, rated voltage ≤ 250 V AC with pollution degree 1-2 according to IEC 60664-1 Caution! The protection class 2 is only valid when the terminal compartment is closed.
UL approval	cULus
CCC approval	Products with a maximum operating voltage of ≤36 V do not bear a CCC marking because they do not require approval.

Accessories**OMH-05**

Mounting aid for round steel ø 12 mm or sheet 1.5 mm ... 3 mm

OMH-07

Mounting aid for round steel ø 12 mm or sheet 1.5 mm ... 3 mm

OMH-21

Mounting bracket

OMH-22

Mounting bracket

OMH-MLV11-K

dove tail mounting clamp

OMH-RLK29

Mounting bracket

OMH-RLK29-HW

Mounting bracket for rear wall mounting

OMH-RL28-C

Protective cover

Other suitable accessories can be found at www.pepperl-fuchs.com

Curves/Diagrams

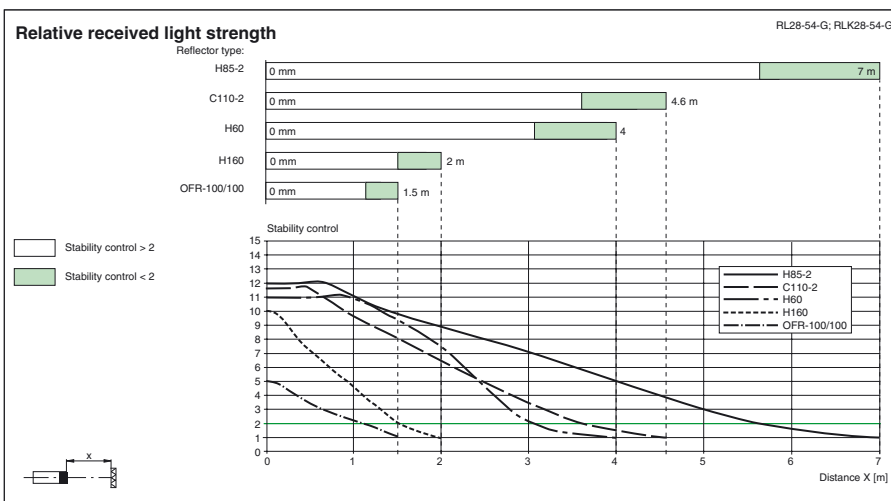
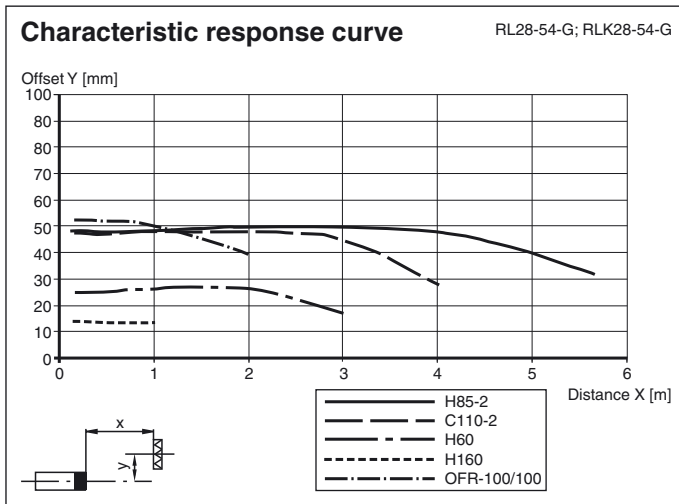

TEACH-IN

- Switch position "N" (standard operation):**
LEDs are lit when the light beam is unobstructed, they flash when the value falls short of the function reserve and they go out when the beam is interrupted.
- Switch position "T" (Teach-in mode):**
After 1 s, the LED flashes slowly (approx. 1.5 Hz). The sensor is now ready to be set for a specific contrast detection value either via the mechanical switch (pos. I, II or III) or an external signal.
- Switch positions "I", "II" and "III" (contrast detection mode)**
Contrast recognition values: I for 10 %, II for 18 %, III for 40 %
 - LED permanently lit: light path unobstructed
 - LED off: element to be sensed detected
 - LED flashes rapidly: detection failure, excessive soiling, function reserve too low.

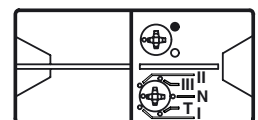

Ext. TEACH-IN input

- The desired contrast recognition capability can be adjusted by applying of a logic „high“ pulse with a certain pulse length when the switch is in position T.
- I: 50 ms (30 ms ... 100 ms)
 - II: 150 ms (100 ms ... 200 ms)
 - III: > 200 ms
- It is possible to change the contrast detection level without re-teaching. For contrast detection mode (Teach-Mode) the stability reserve must be at least 2.5 (see curve „relative received light strength“).

Timer functions

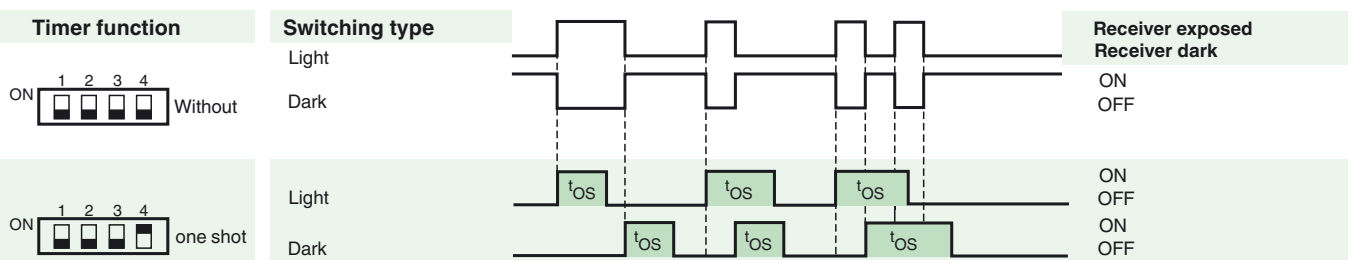

The Light-/Dark-Switch (Left, outer switch) is shown in the "Dark ON" position.

Release date: 2011-12-21 10:24 Date of issue: 2011-12-21 116635_eng.xml

Type	Description	Notes
-Z	one shot timer	Fixed time interval 0.02 s

Additional information

Mounting instructions:

The sensor is held in place by two pass-through drill holes for M5. The surface underneath must be flat to prevent the housing from moving when it is tightened into position. We recommend securing the nuts in place with spring screws to prevent the sensor from going out of adjustment.

Outdoor mounting:

The sensors must be protected from shock and splashed water. It may be necessary to provide a covering.

Adjustment:

Align the unit to the reflector in the "N" switch setting. The yellow LED must be lit constantly. Move the switch to the "T" setting and wait for about 1 sec. until the yellow LED starts flashing slowly.

Move the switch to the setting for the desired contrast detection level: "I" for 10%, "II" for 18%, "III" for 40%.

or

In switch setting "T", select the appropriate contrast detection level by applying a pulse through the control lead to connection pin 5 (see "TEACH-IN").

Contrast detection levels:

The output becomes inactive if dirt and dust make it impossible to readjust the setting. In this case the yellow LED will flash quickly.

If dirt and dust continue to accumulate, detection of slight contrasts can no longer be guaranteed.