

CE

Model Number

SC PS 120-240VAC

Mains part for evaluation devices with alternating current supply

Primary cycled power supply

Dimensions

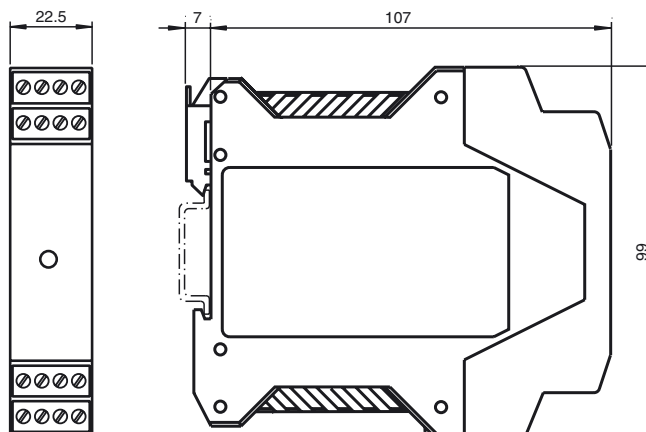

Technical data

General specifications

Approvals	CE, cULus
MTBF	500000 h acc. to IEC 1709 (SN 29 500)

Indicators/operating means

Function display	LED green
------------------	-----------

Electrical specifications

Operating voltage	120 ... 230 V AC 100 ... 250 V DC
Protection class	II
Efficiency	> 80 %
Ripple	3 %

Input

Input voltage	120 ... 230 V AC
Input current	0.2 A at 230 V AC

Output

Switching voltage	24 V DC
Switching current	650 mA

Standard conformity

Standards	EN 50178 EN 60950
-----------	----------------------

Ambient conditions

Ambient temperature	-25 ... 60 °C (248 ... 333 K)
Storage temperature	-40 ... 85 °C (233 ... 358 K)
Shock resistance	IEC 68-2-27 30 g for 18 ms in all three room axes
Degree of soiling	2

Mechanical specifications

Protection degree	IP20
Material	
Housing	plastic
Mass	140 g