

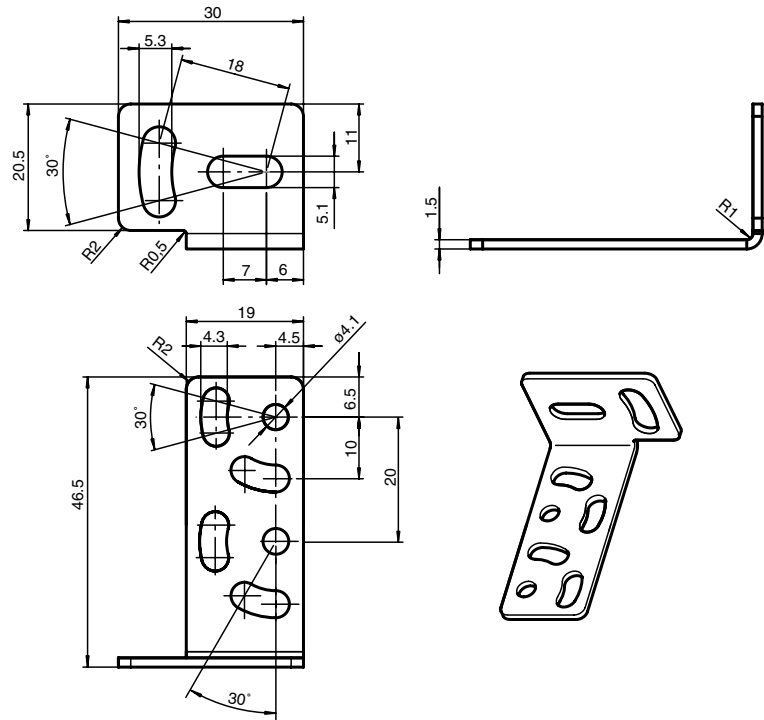

Dimensions



Model number

OMH-MLV12-HWG

Mounting bracket for series MLV12 sensors

Features

- Mounting bracket
- Simple and fast mounting

Technical data

Mechanical specifications

Material	Metal sheet (steel), nickel-plated
Mass	approx. 15 g

suitable series

Series	MLV12
Safety Series	SL12, SLA12