



CE

Model Number

REF-MCLIP15HT

Reflector with Micro-structure, round \varnothing 15 mm, snap-in, high temperature applications

Features

- Simple installation with snap-in fastener
- Micro-structure
- With extended temperature range up to 110 °C (230 °F)

Dimensions

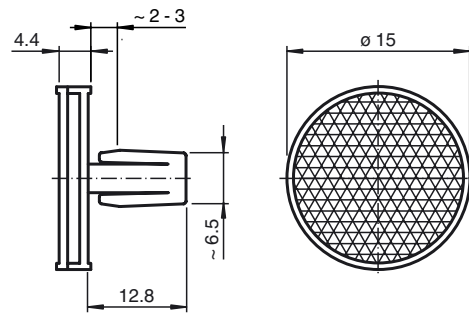

Technical data

General specifications

Construction type	circular
Tripel height	approx. 0.8 mm

Ambient conditions

Ambient temperature	-20 ... 110 °C (-4 ... 230 °F)
---------------------	--------------------------------

Mechanical specifications

Dimensions	Diameter: 15 mm
Mounting	Snap-in