

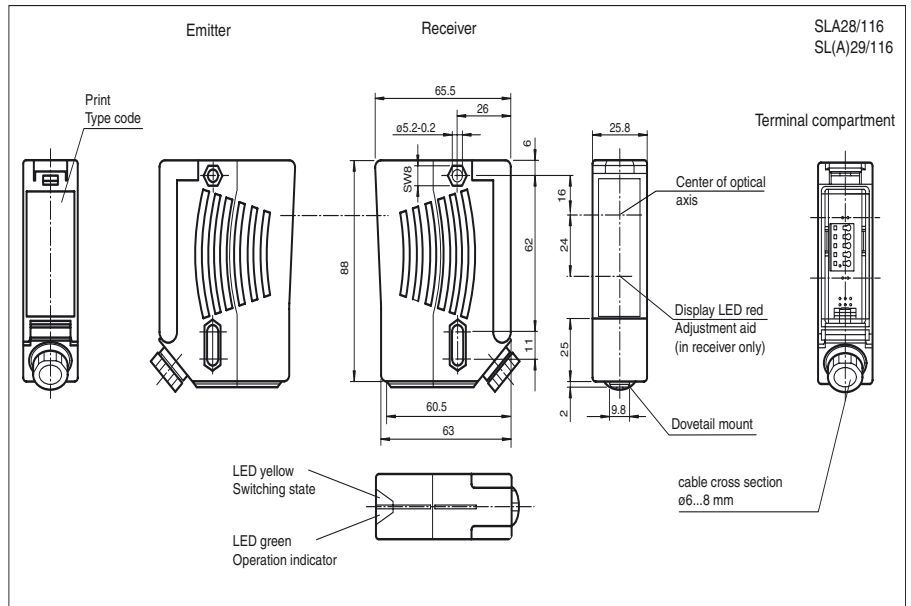

Dimensions



SLA28/116
SL(A)29/116

Model Number

SLA28/106/116

Safety thru-beam sensor
with terminal compartment

Features

- Detection range up to 65 m
- Self-monitoring (type 4 according to IEC/EN 61496-1)
- Red transmission light
- Integrated alignment aid
- Clearly visible LED functional display and pre-fault indicator on the receiver
- Extended temperature range up to -35 °C with heated front panel
- Sturdy housing
- Waterproof, protection class IP67
- Operation on control units of SB4 (SafeBox)

Accessories

OMH-21
Mounting aid

Electrical connection

Design with terminal room
Receiver:

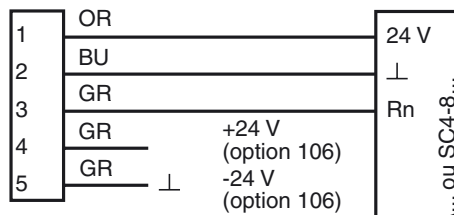

Emitter:

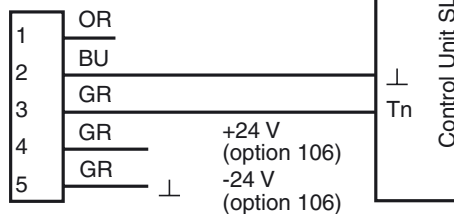

Release date: 2009-12-14 11:09 Date of issue: 2009-12-14 11:2351_ENG.xml

Additional accessories can be found in the Internet.

Technical data

General specifications

Effective detection range	0.2 ... 30 m
Number of protective field beams	1
Light source	LED
Light type	red, modulated light
Approvals	TÜV
Tests	IEC/EN 61496
Safety type according to IEC/EN 61496	4
Marking	CE, cULus
Obstacle size	static: 30 mm dynamic: 40 mm (at v = 1.6 m/s of the obstacle)
Alignment aid	LED red in receiver
Angle of divergence	< 5 °

Functional safety related parameters

Safety Integrity Level (SIL)	SIL 3
Performance level (PL)	PL e
Category	Cat. 4
Mission Time (T _M)	20 a
PFH _d	4.4 E-10

Indicators/operating means

Function display	LED yellow/green in receiver: off: Interruption yellow: transmission green: reception with sufficient stability control
Pre-fault indication	LED functional display yellow

Electrical specifications

Operating voltage	U _B	Power supply via control unit
-------------------	----------------	-------------------------------

Ambient conditions

Ambient temperature	-40 ... 60 °C (233 ... 333 K) with heated optical face, fixed voltage 24 V DC ± 20 %/50 mA	
Storage temperature	-20 ... 70 °C (253 ... 343 K)	
Relative humidity	max. 95 %, not condensing	

Mechanical specifications

Protection degree	IP67	
Connection	Cable screwed connection M16 , terminal compartment, lead cross-section 1.5 mm ²	
Material	Housing: ABS plastic, RLA 1021 (yellow) painted Optical face: Plastic pane	
Mass	Per 70 g	

General information

System components	Emitter: SLA28-T/106/116 Receiver: SLA28-R/106/116	
-------------------	---	--

Curves/Diagrams

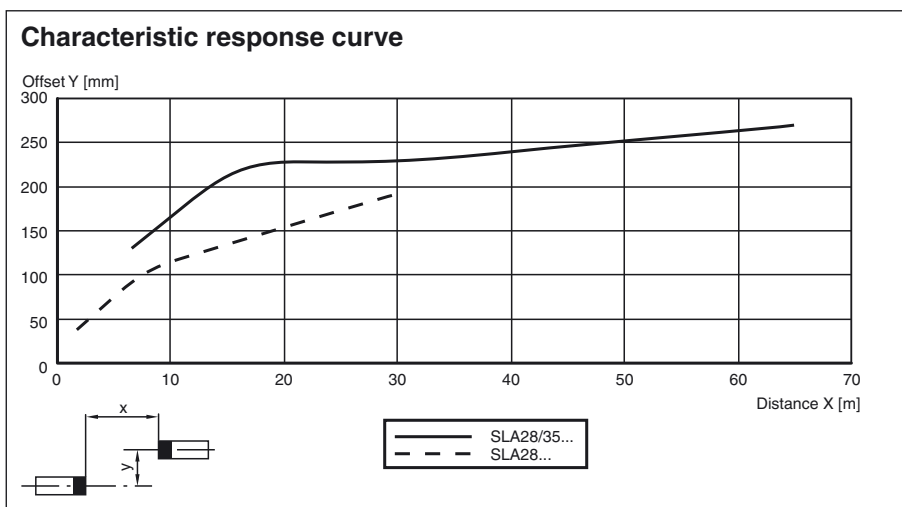

Release date: 2009-12-14 11:09 Date of issue: 2009-12-14 11:25 ENG.xml

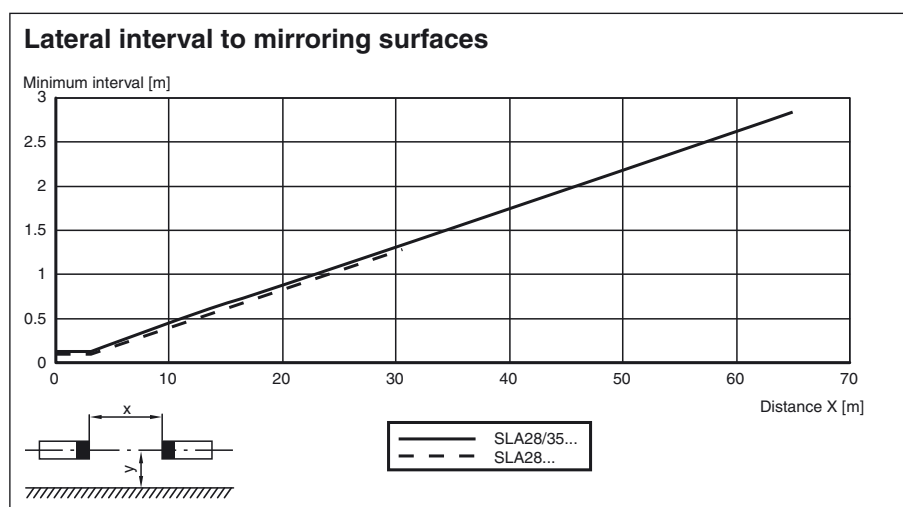
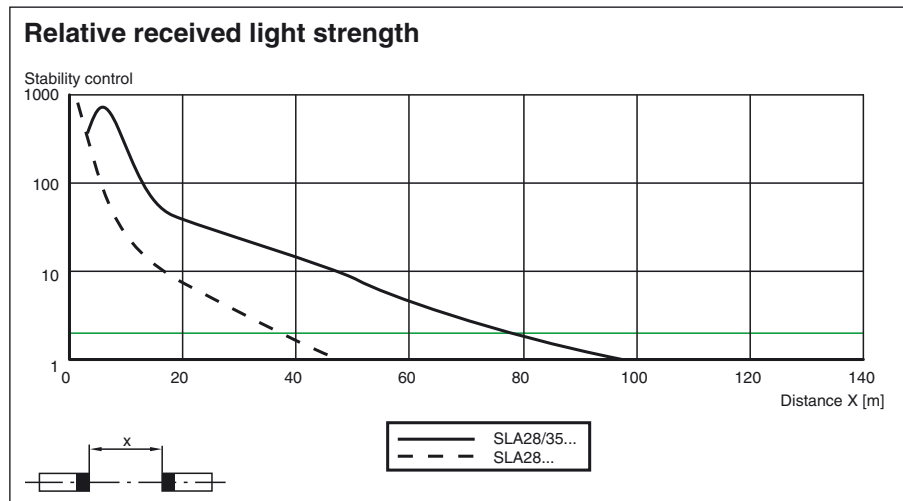

Additional information

For much easier alignment even for long distance applications, an additional red LED is located in the receivers optics:

- LED constantly illuminated:
signal strength < switching level
- LED flashes:
signal strength is between 1-fold switching level and 2-fold switching level
- LED off:
signal strength \geq 2-fold switching level (function reserve)

System accessories

Control units

SLVA4-K plus
 SLVA8-K
 SC4-8

Cable sockets

Option /105:

straight: V15-G-2M-PVC
 V15-G-5M-PVC
 V15-G-10M-PVC
 angled: V15-W-2M-PVC
 V15-W-5M-PVC
 V15-W-10M-PVC

Release date: 2009-12-14 11:09 Date of issue: 2009-12-14 11:2351_ENG.xml

Option /116: no

Mounting aids

OMH-21
OMH-22
OMH-05
OMH-MLV11-K

Further accessories

Laser alignment aid
BA SLA28

Muting Set
MS SLP/SLA28

Redirection mirror
SLA-1-M